

Area of Cross Section Through Ship

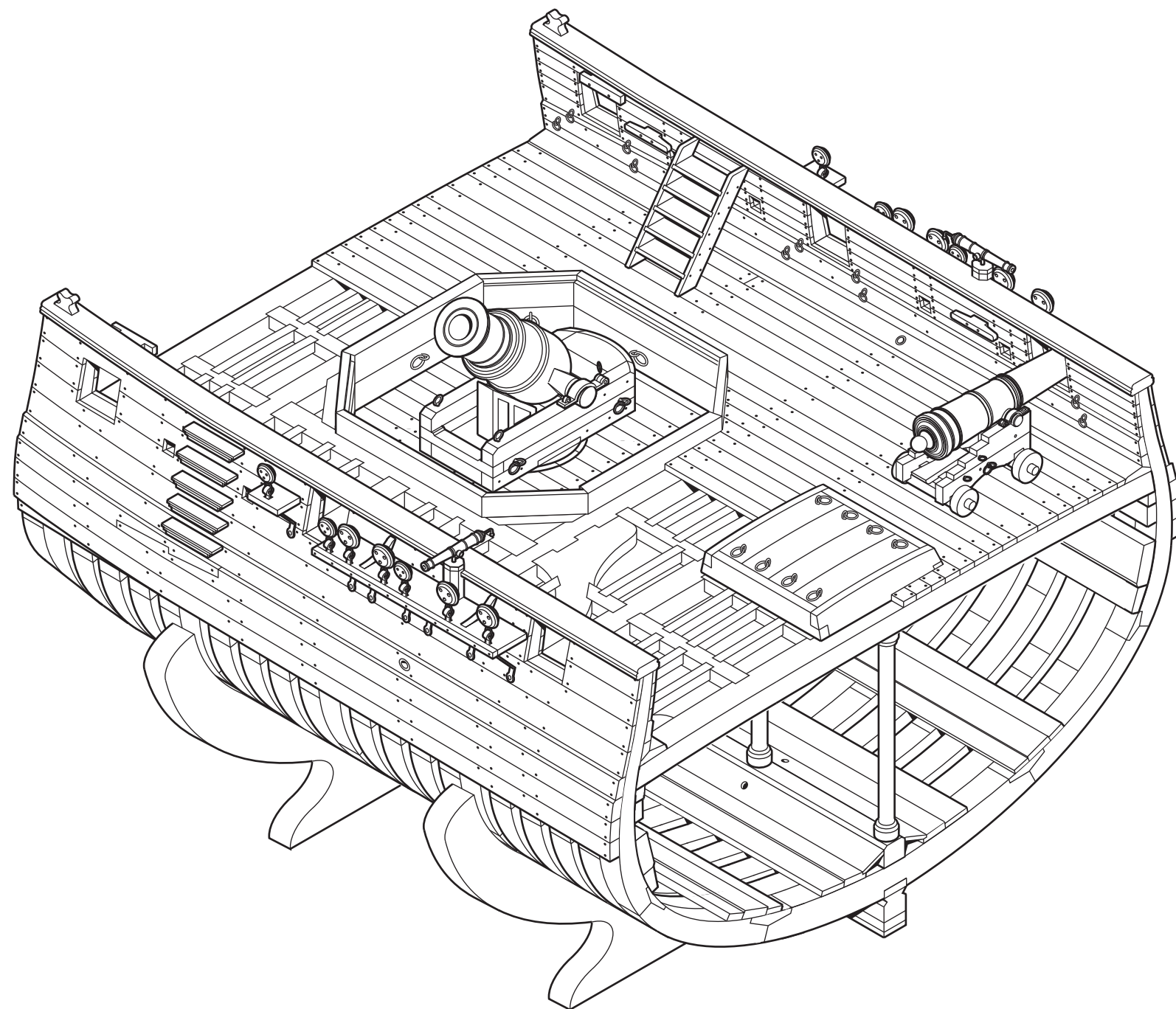

Plans created from the sources:  
"Anatomy of the ship - The Bomb Vessel Granado -1742"  
by Peter Goodwin, and original bomb vessel drawings by Thomas Slade.



[www.modelshipbuilder.com](http://www.modelshipbuilder.com)



**CROSS SECTIONAL MODEL**

Drawn by Jeff Staudt - February, 2010

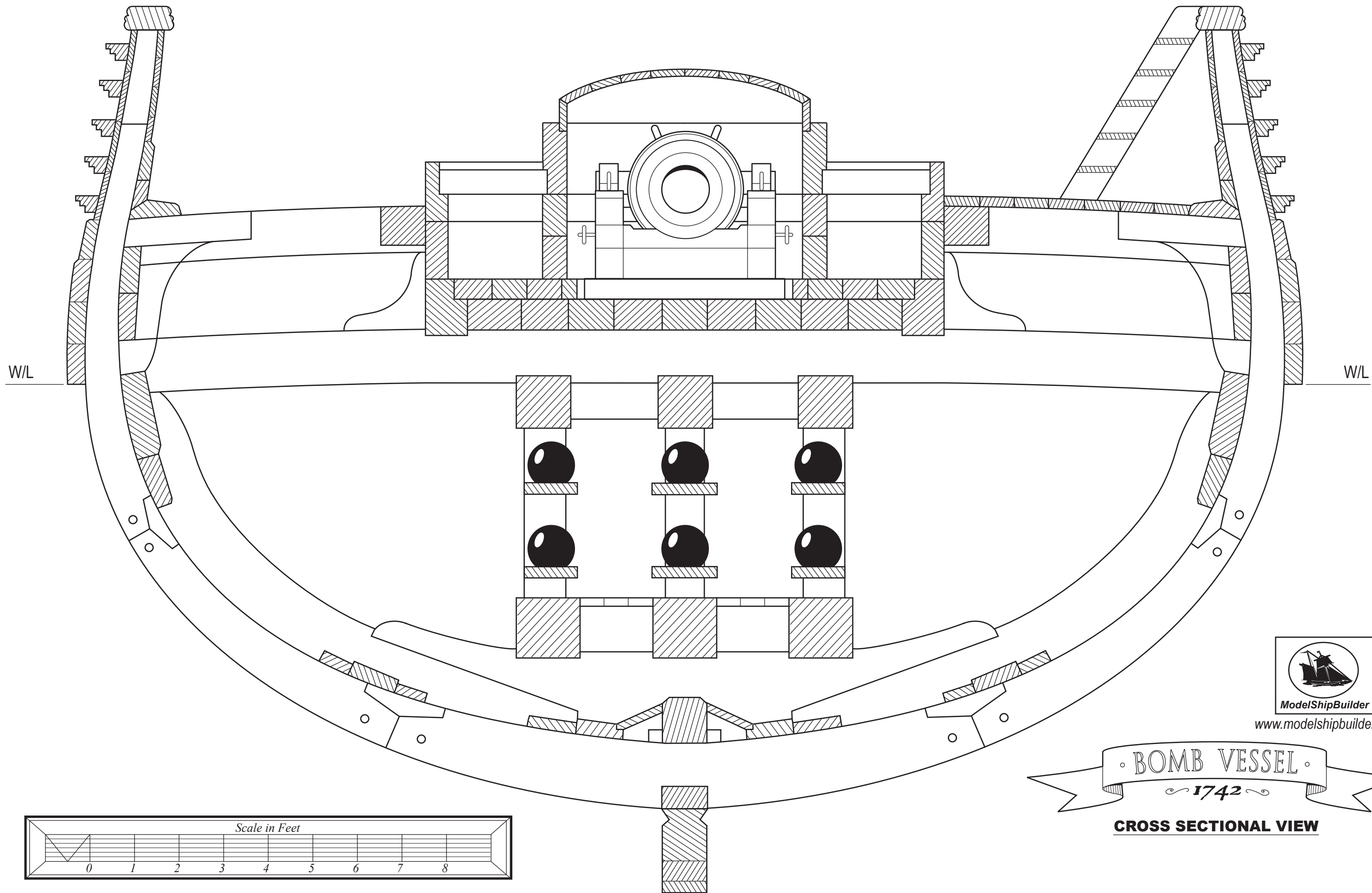

www.modelshipbuilder.com

• BOMB VESSEL •  
1742

**CROSS SECTIONAL VIEW**

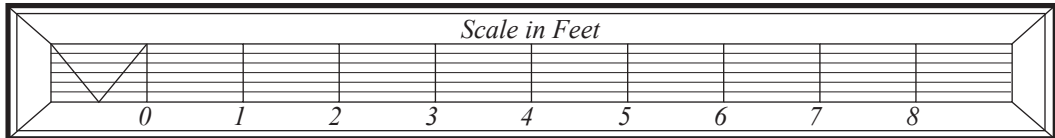



www.modelshipbuilder.com

# BOMB VESSEL

1742

## KEEL & HOG

- 1. Keel
- 2. False Keel (Upper)
- 3. False Keel (Lower)
- 4. Hog

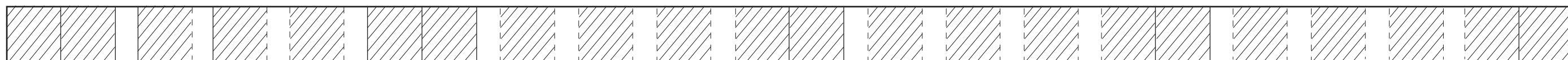
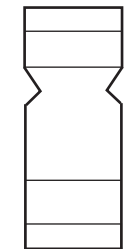
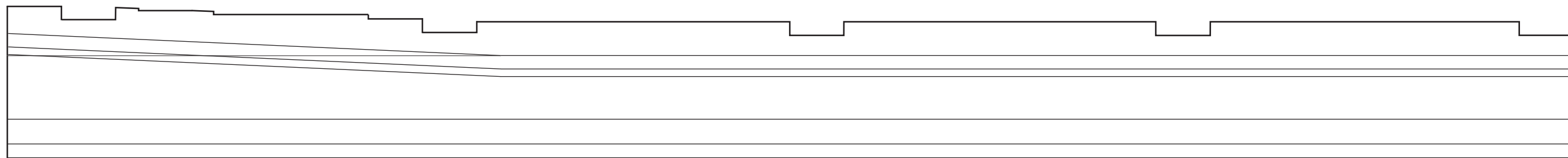
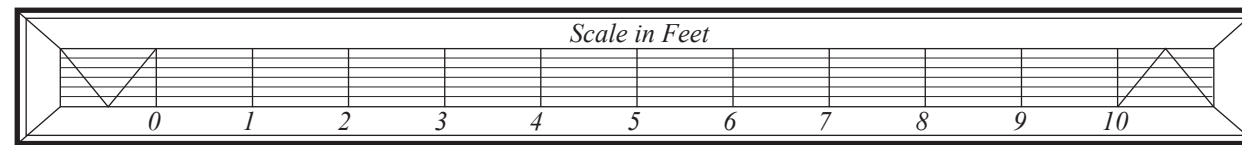
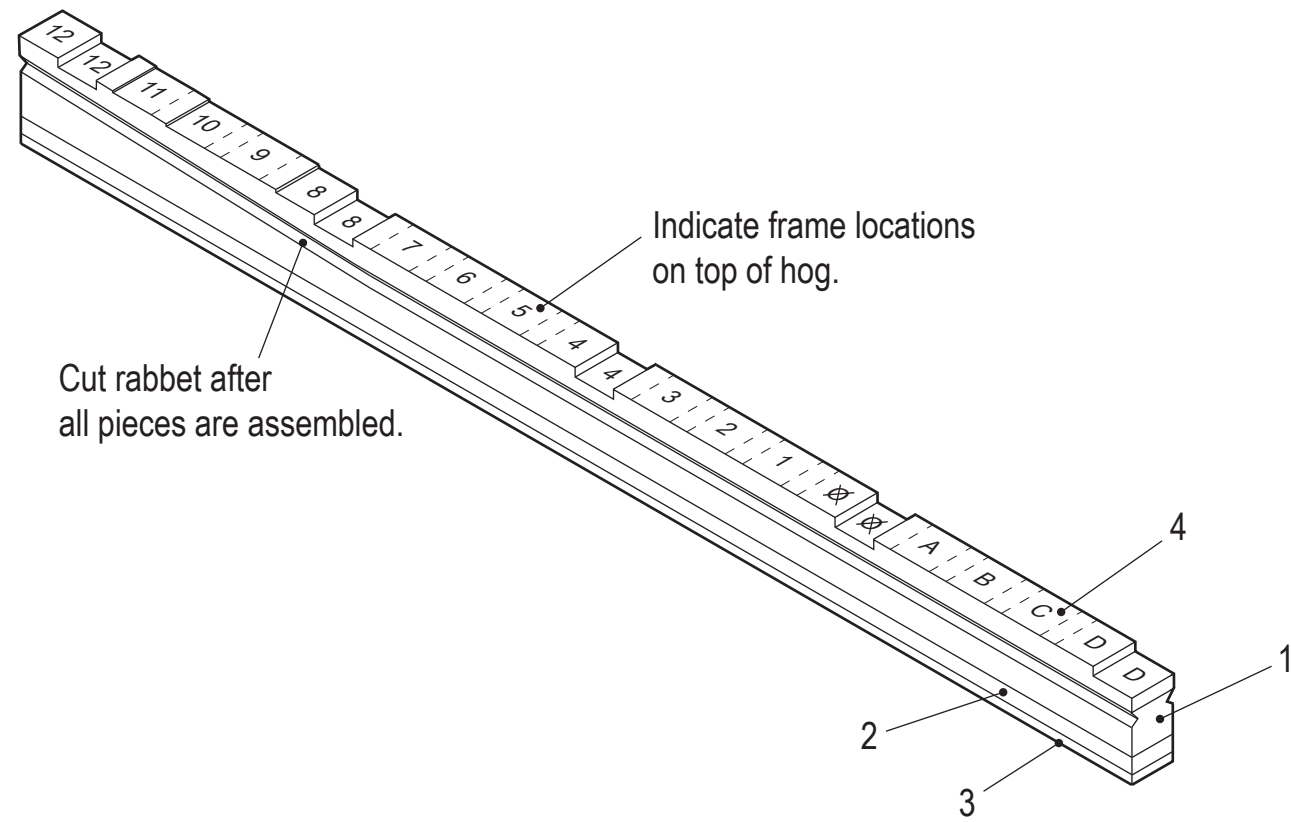

12 11 10 9 8 7 6 5 4 3 2 1 Ø A B C D

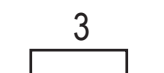
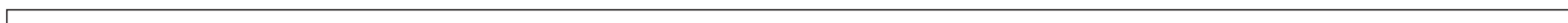
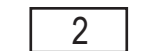
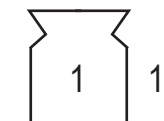
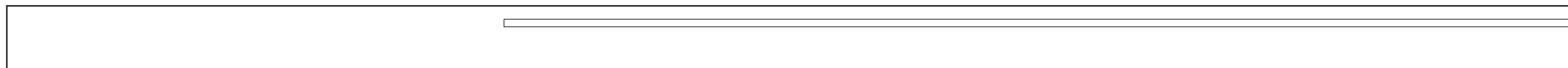

D1



www.modelshipbuilder.com

· BOMB VESSEL ·  
1742

**DOUBLE FRAME D1**

DECK CLAMP

WL

MORTAR PIT CLAMP

D1

D1

D1

D1

D1

Scale in Feet

0 1 2 3 4 5 6 7 8

D1



www.modelshipbuilder.com



**DOUBLE FRAME D2**

D2

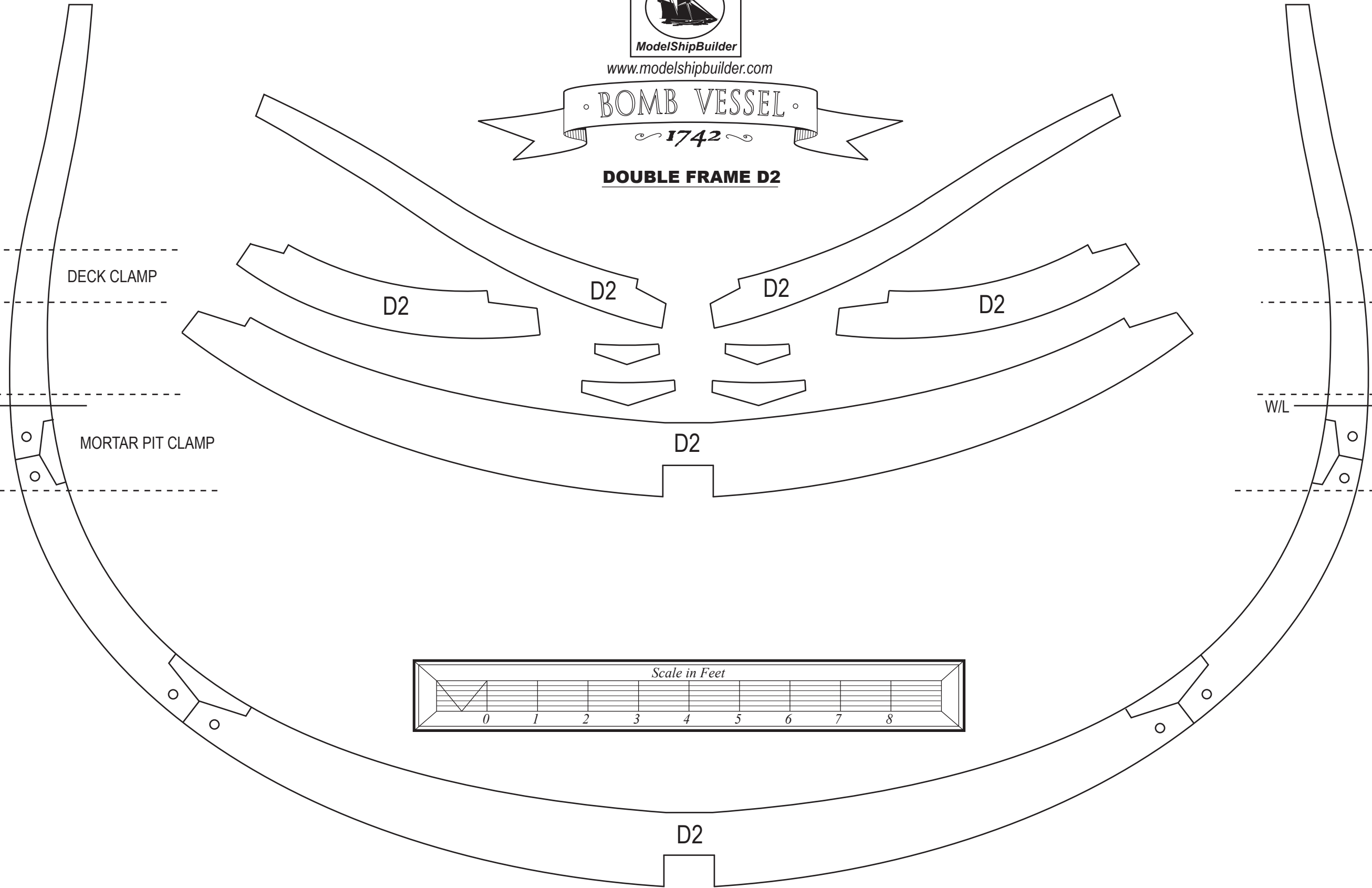
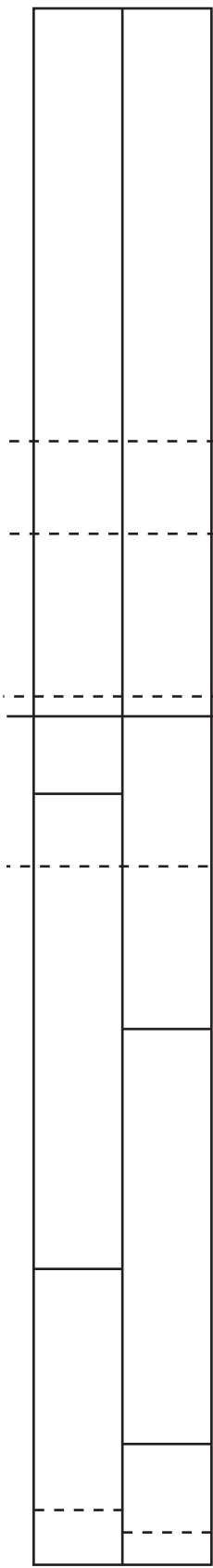

DECK CLAMP

MORTAR PIT CLAMP

W/L

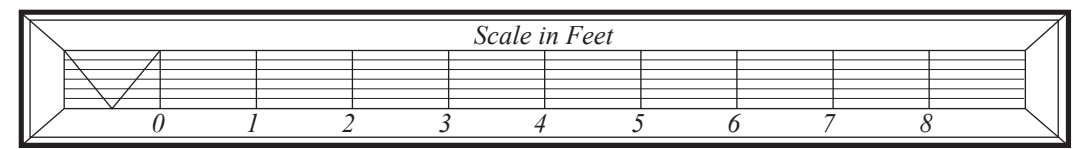

D2



www.modelshipbuilder.com



**SINGLE FRAME C**

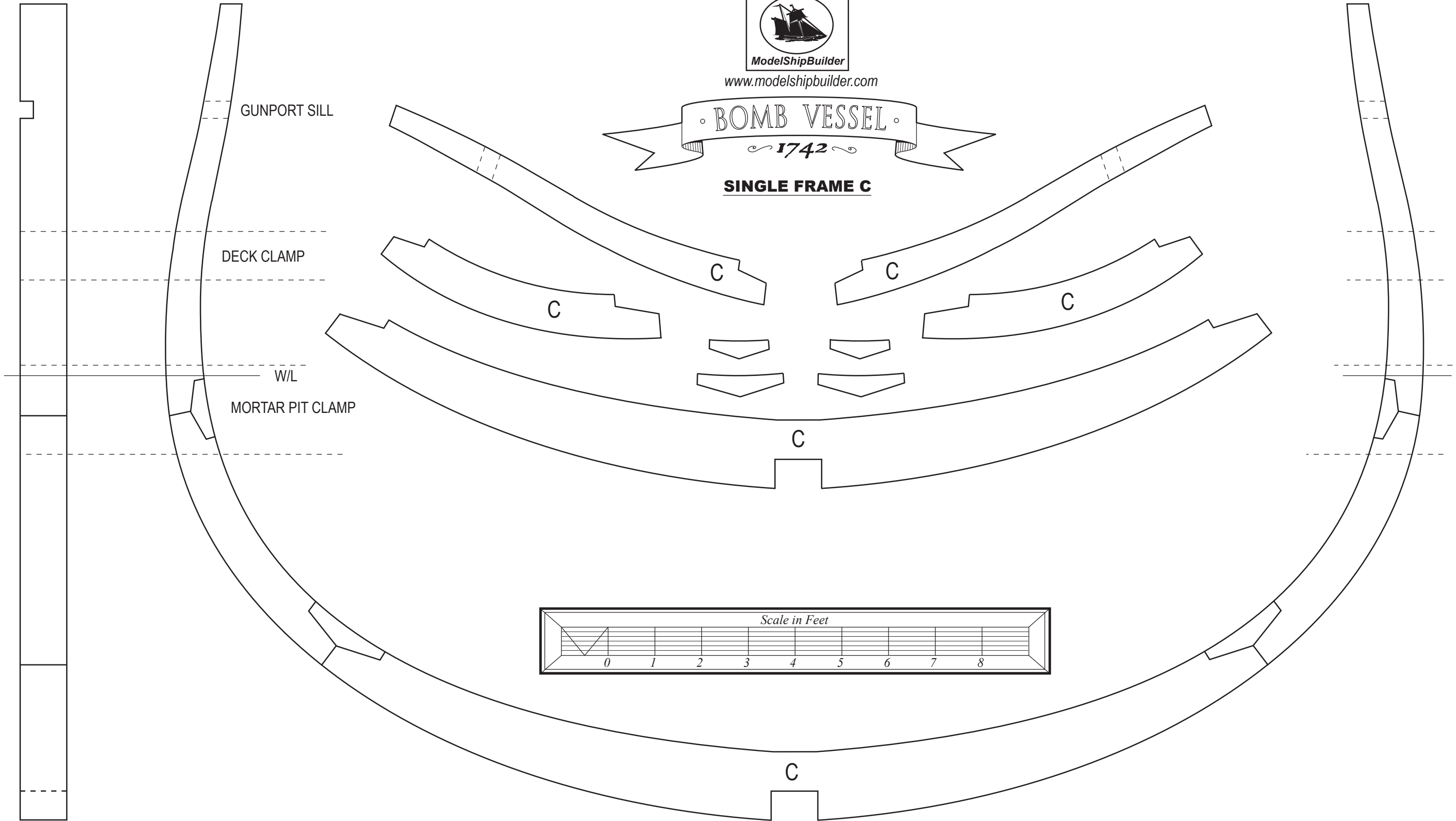



ModelShipBuilder

www.modelshipbuilder.com



• BOMB VESSEL •

1742

**SINGLE FRAME B**

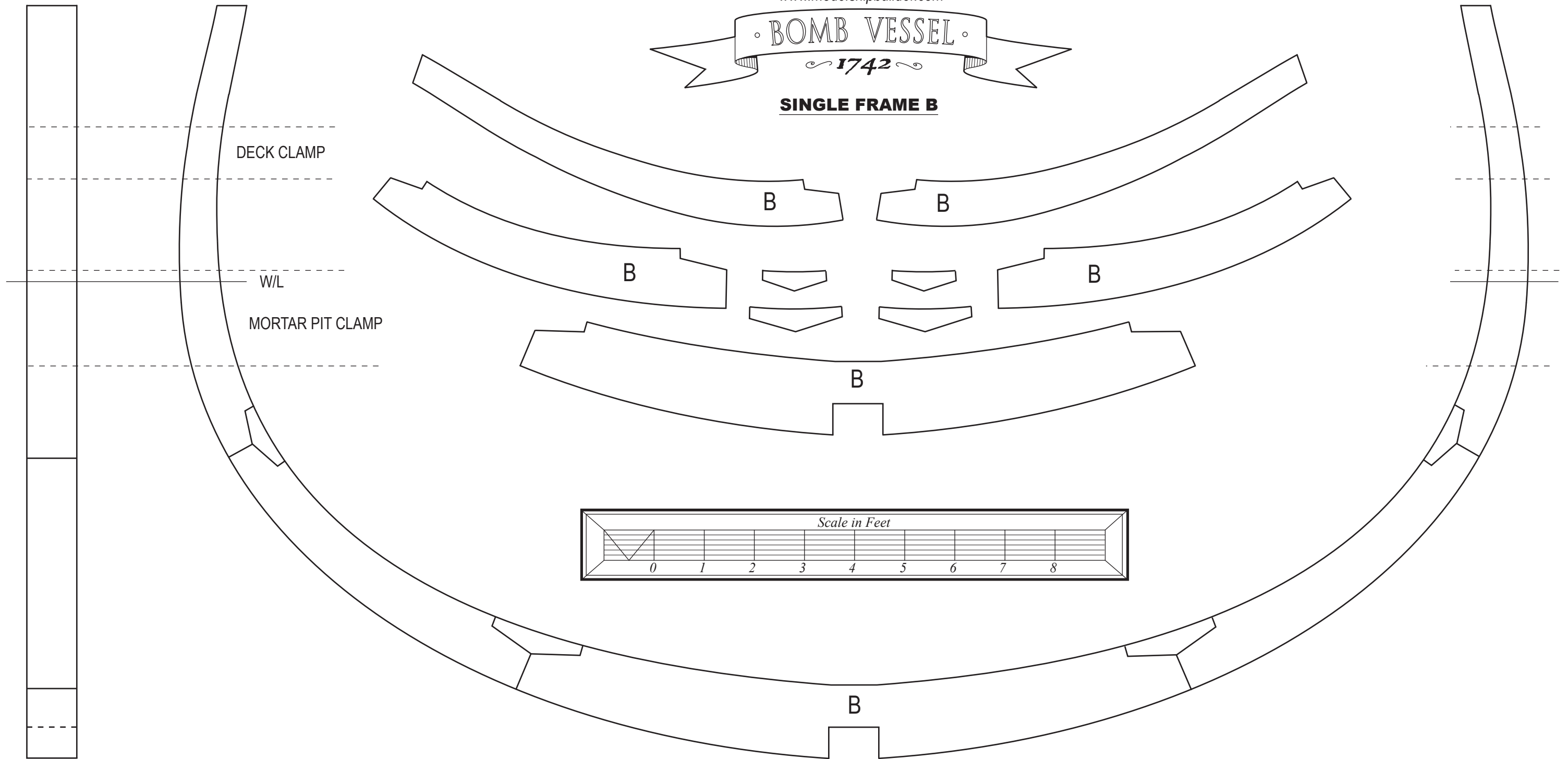



ModelShipBuilder  
www.modelshipbuilder.com



**SINGLE FRAME A**

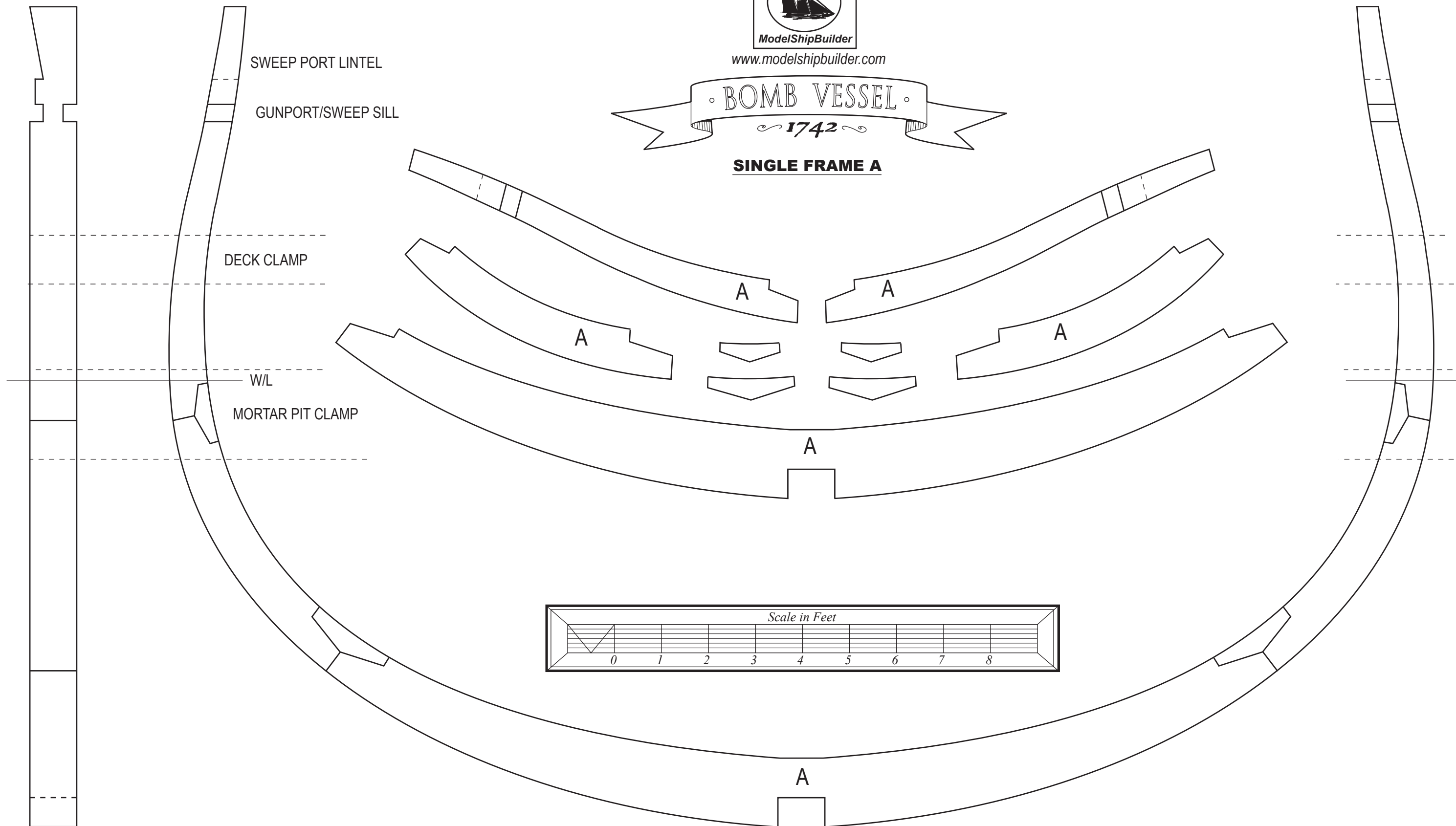



www.modelshipbuilder.com



**MIDSHIP FRAME 1**

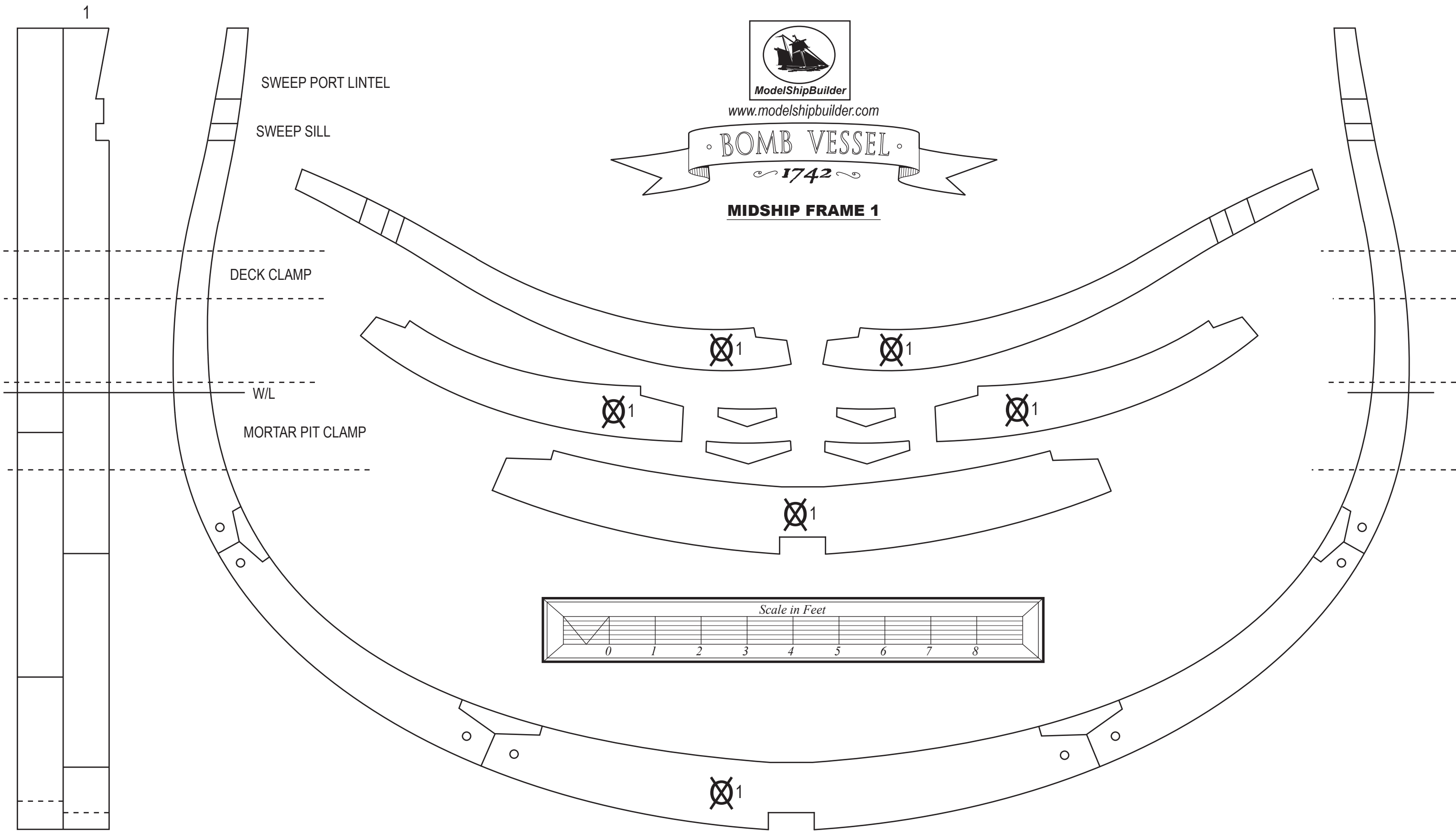

2



ModelShipBuilder

www.modelshipbuilder.com

◦ BOMB VESSEL ◦

1742

**MIDSHIP FRAME 2**

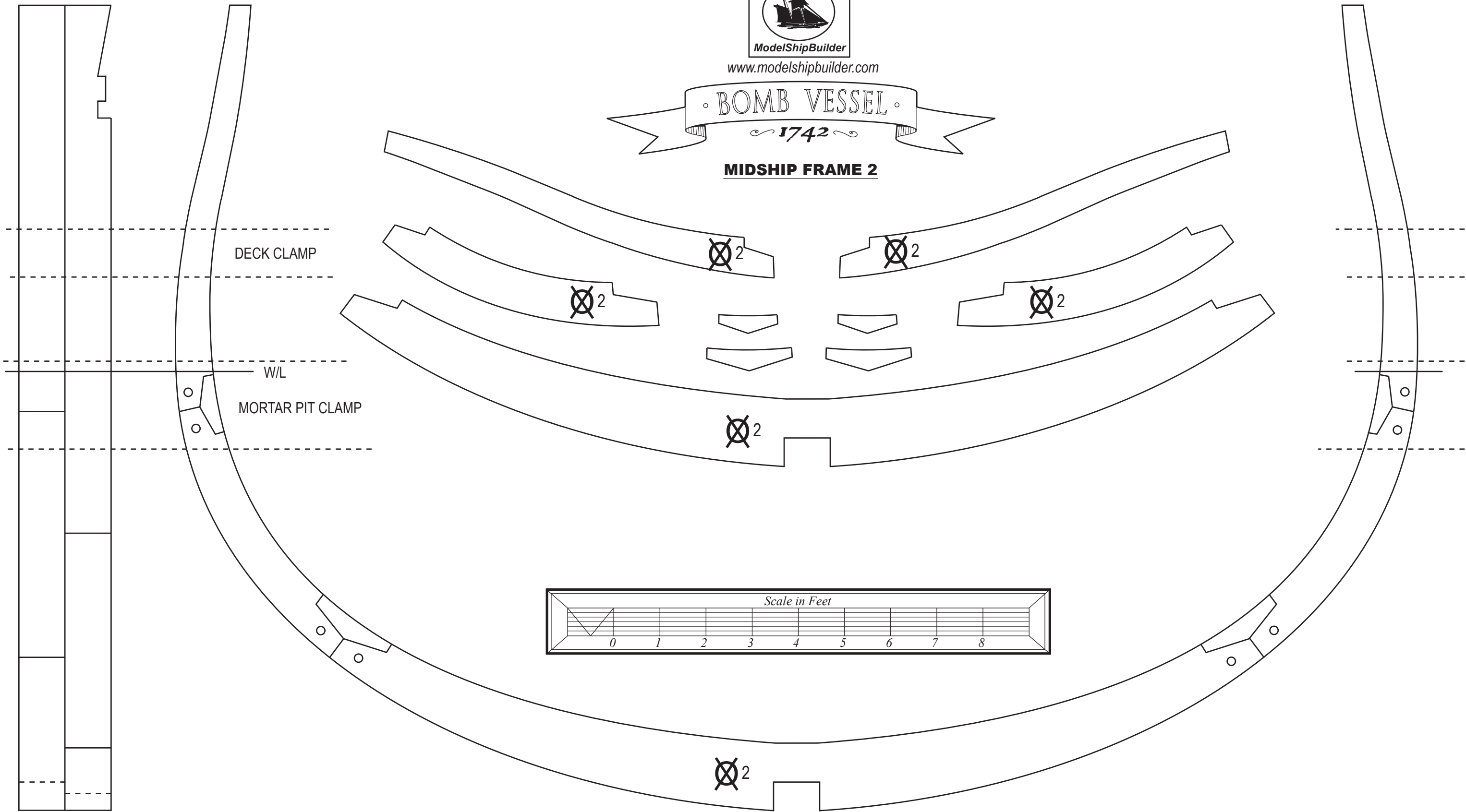



ModelShipBuilder

www.modelshipbuilder.com

• BOMB VESSEL •  
1742

**SINGLE FRAME 1**

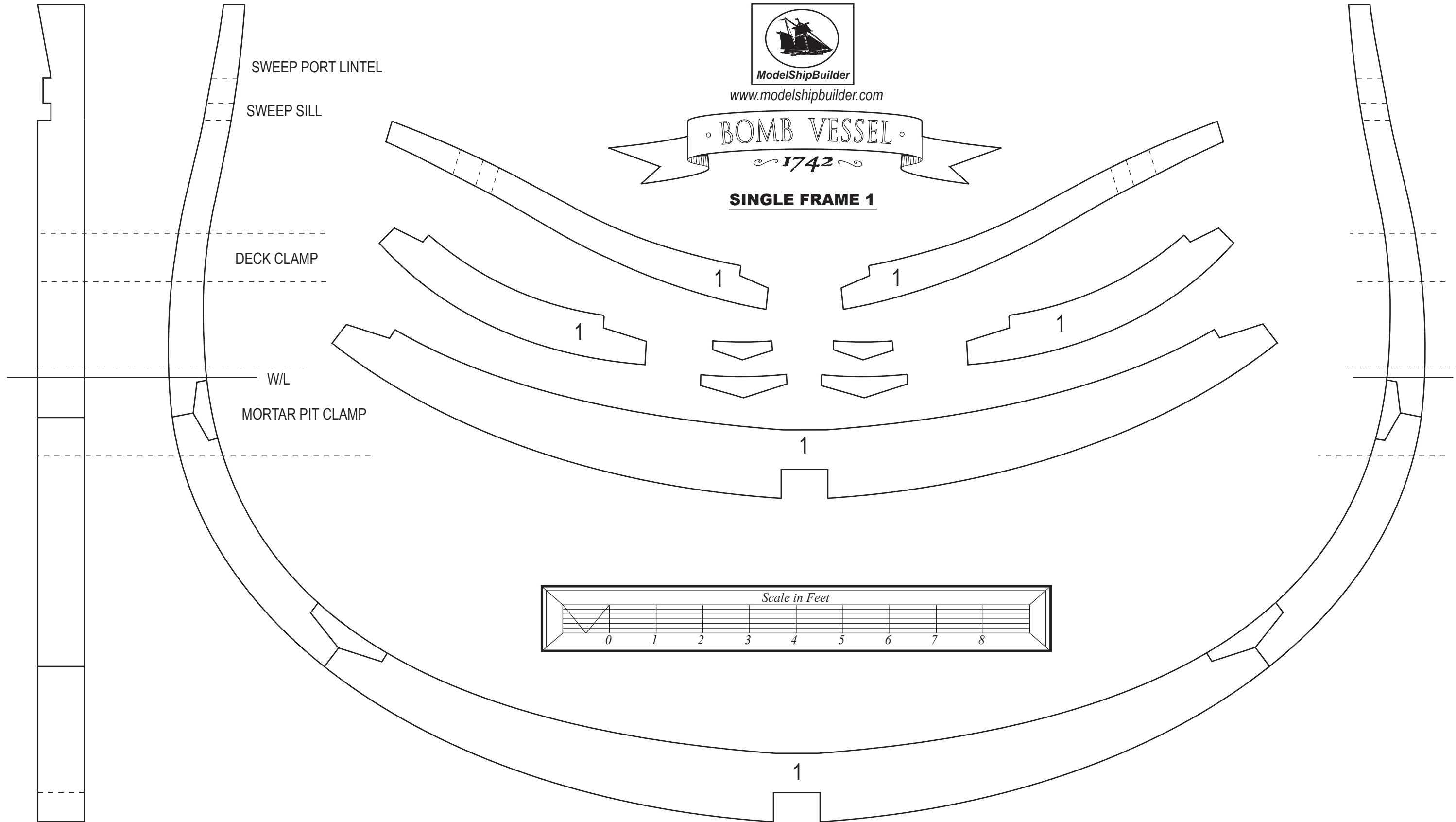



ModelShipBuilder

www.modelshipbuilder.com



**SINGLE FRAME 2**

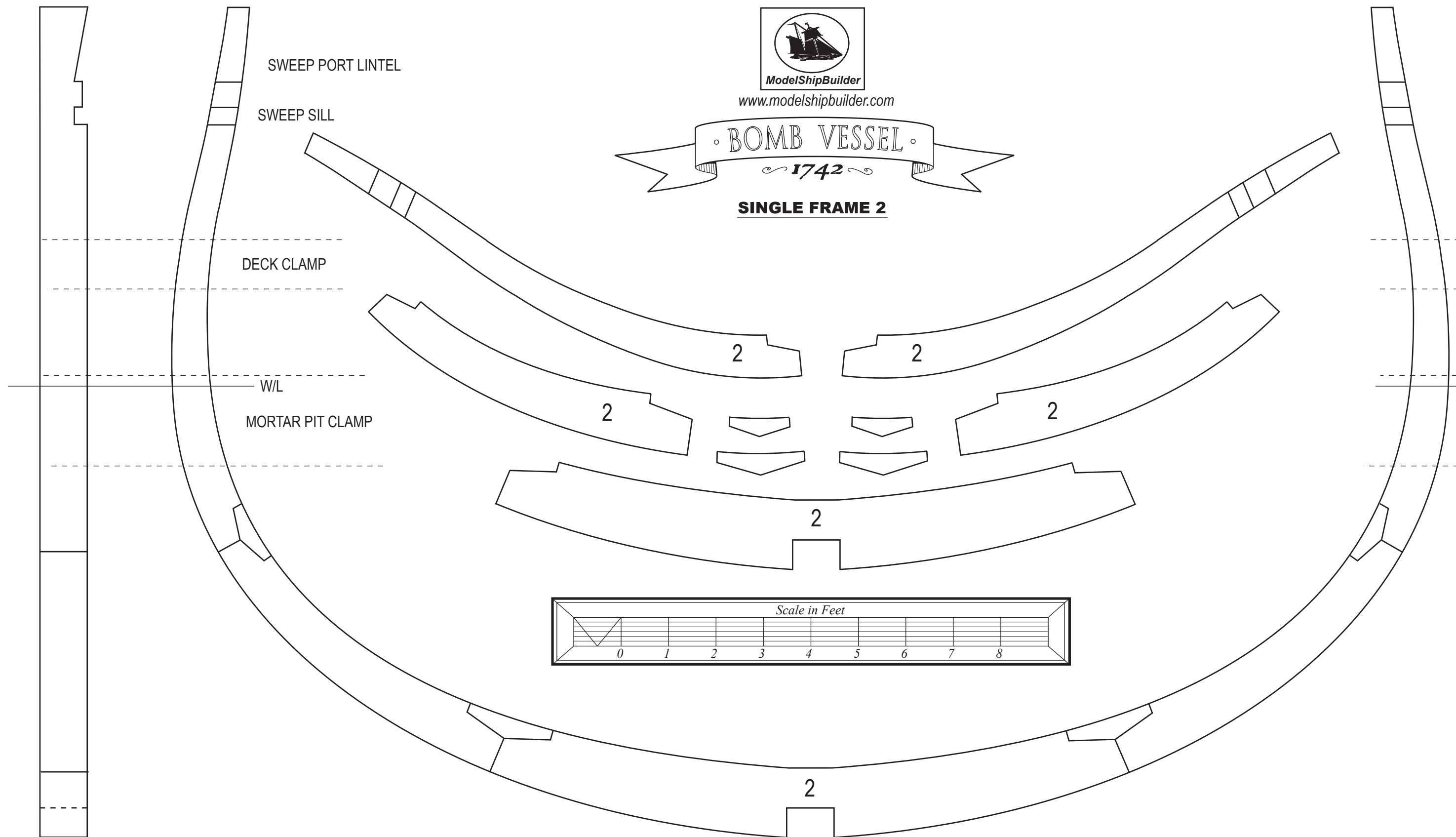



ModelShipBuilder

www.modelshipbuilder.com

◦ BOMB VESSEL ◦  
1742

**SINGLE FRAME 3**

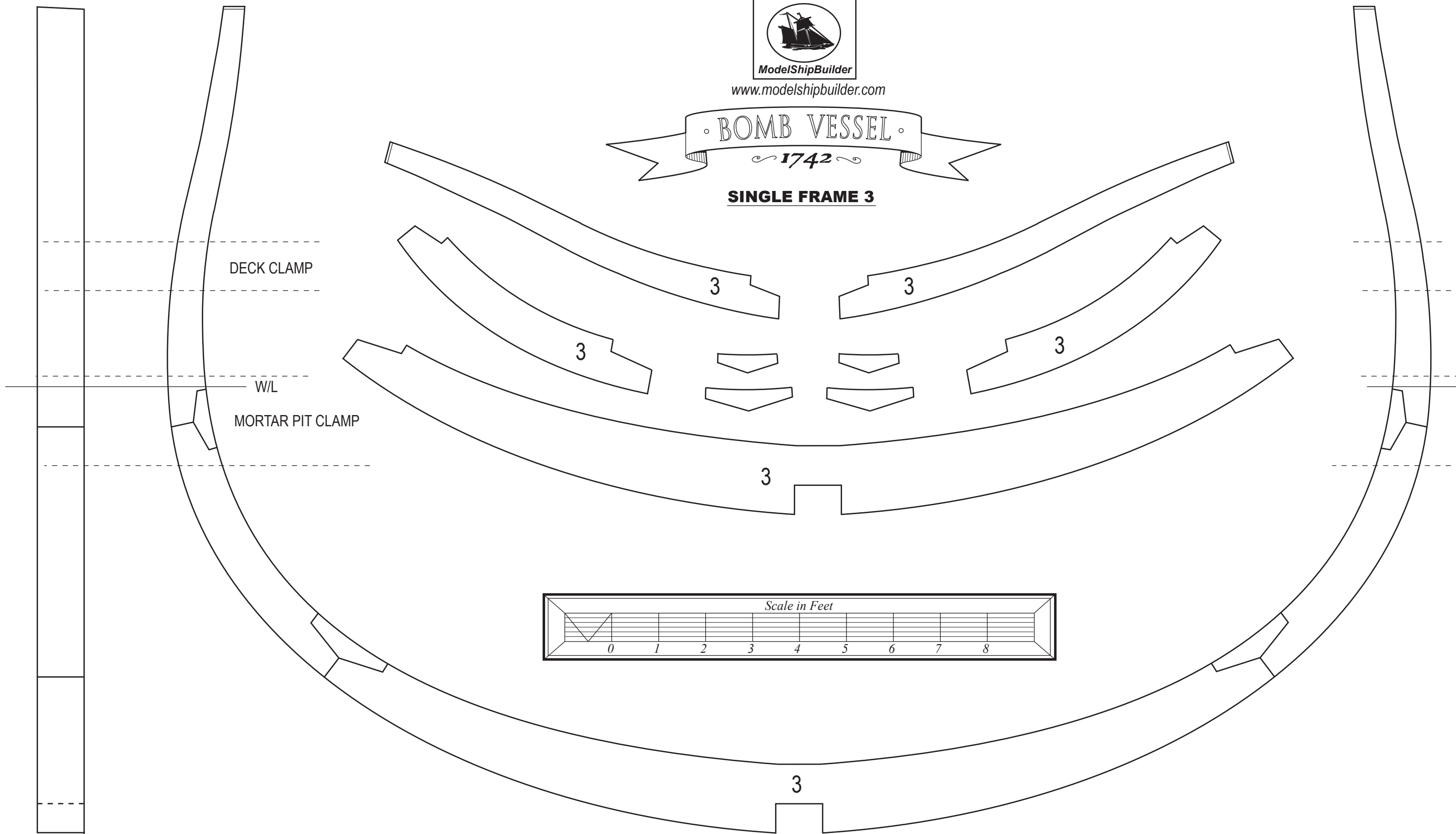



www.modelshipbuilder.com



**DOUBLE FRAME 4A**

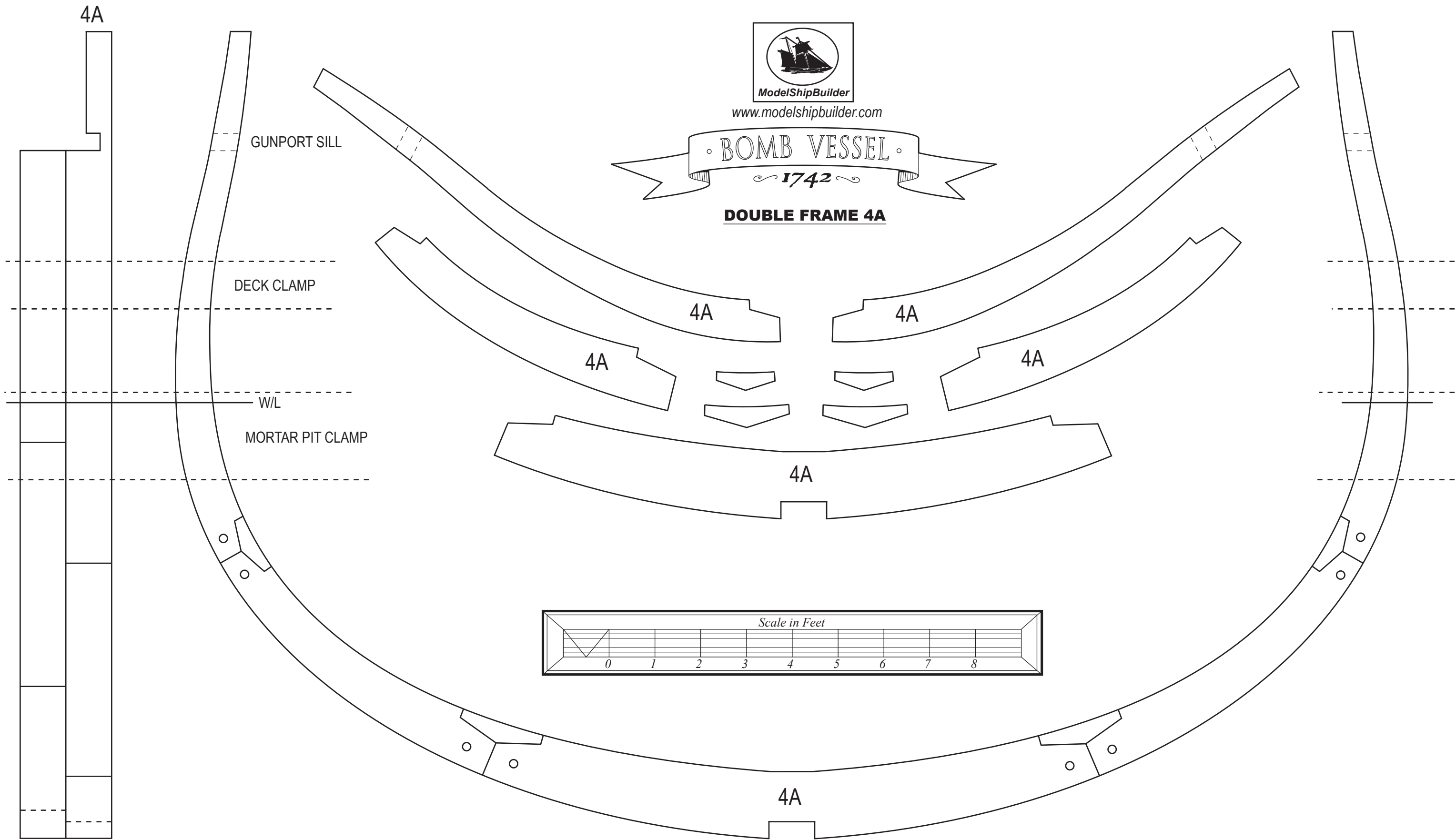



ModelShipBuilder  
www.modelshipbuilder.com



**DOUBLE FRAME 4B**

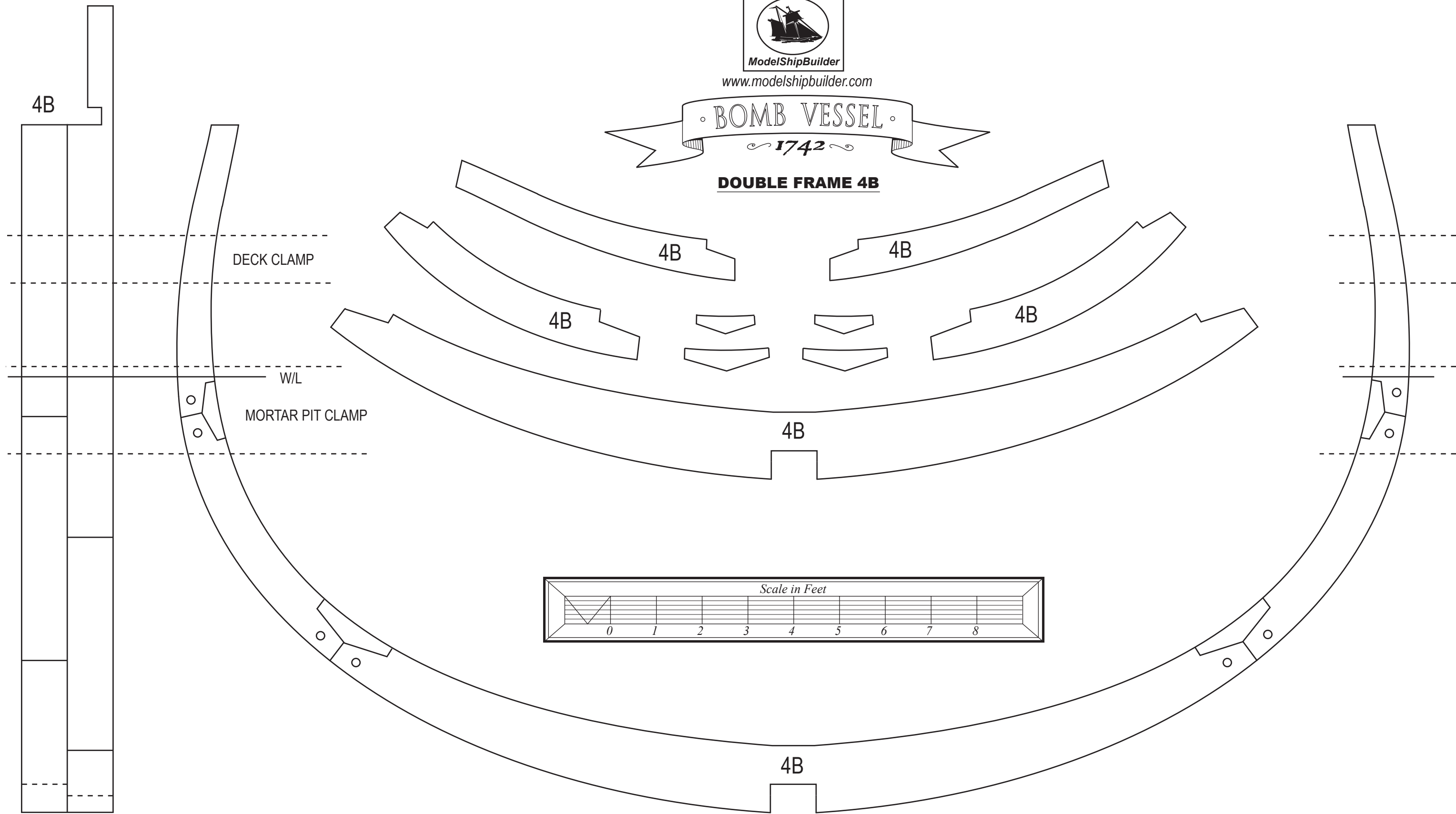



ModelShipBuilder

www.modelshipbuilder.com



**SINGLE FRAME 5**

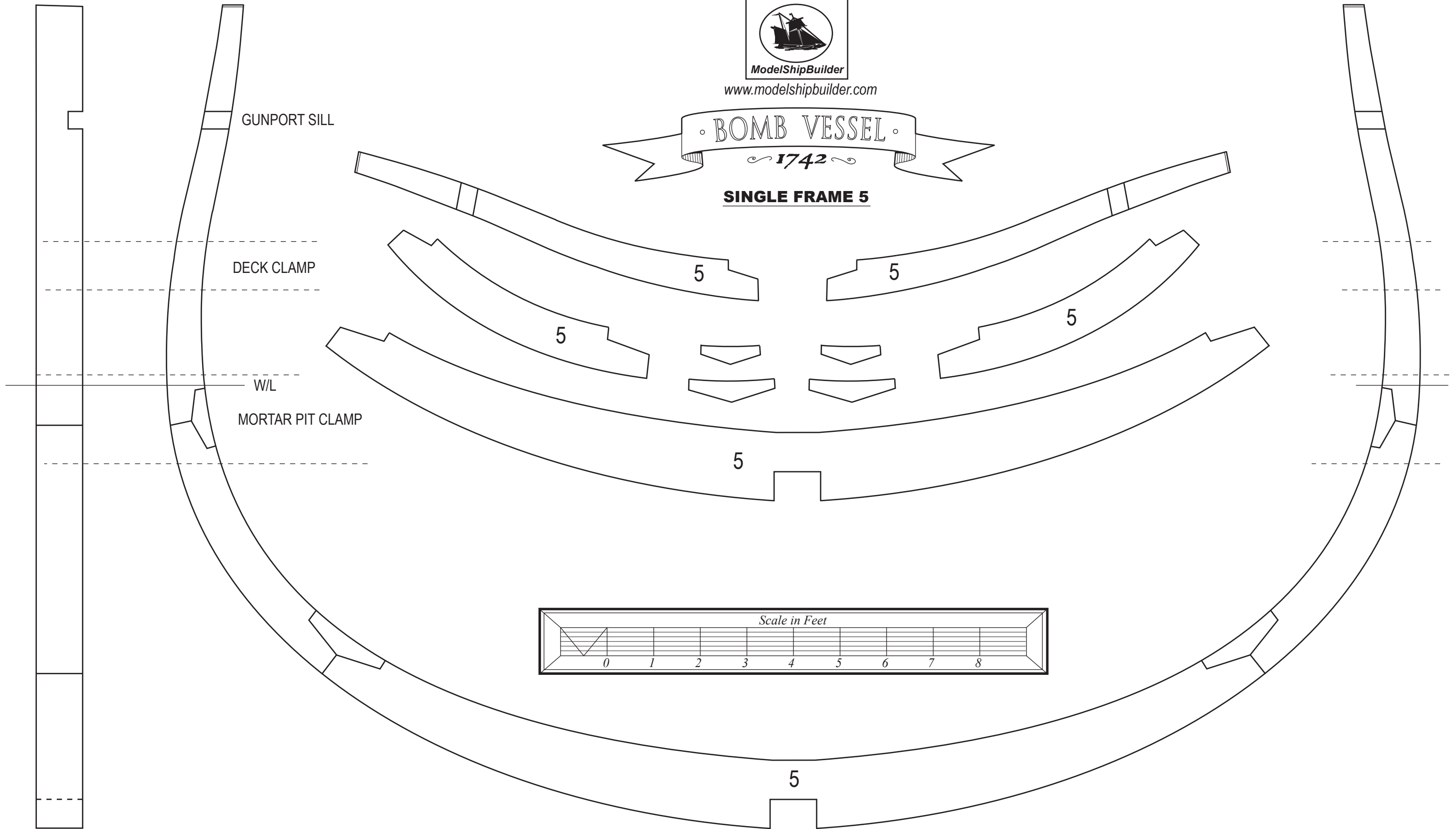



www.modelshipbuilder.com



**SINGLE FRAME 6**

SWEEP PORT LINTEL

SWEEP SILL

DECK CLAMP

W/L

MORTAR PIT CLAMP

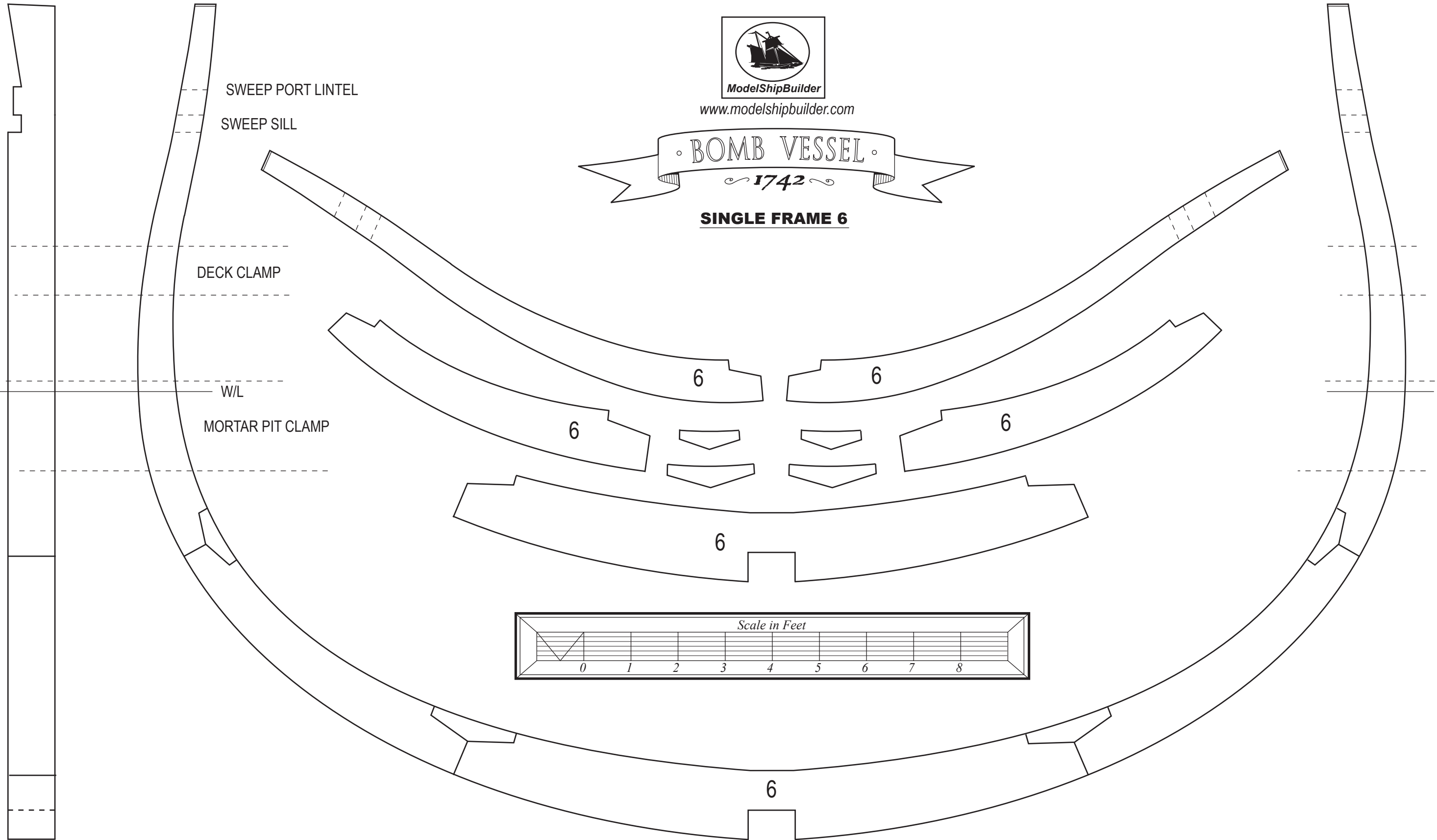
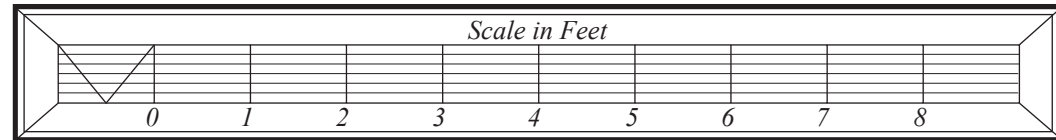



www.modelshipbuilder.com



**SINGLE FRAME 7**

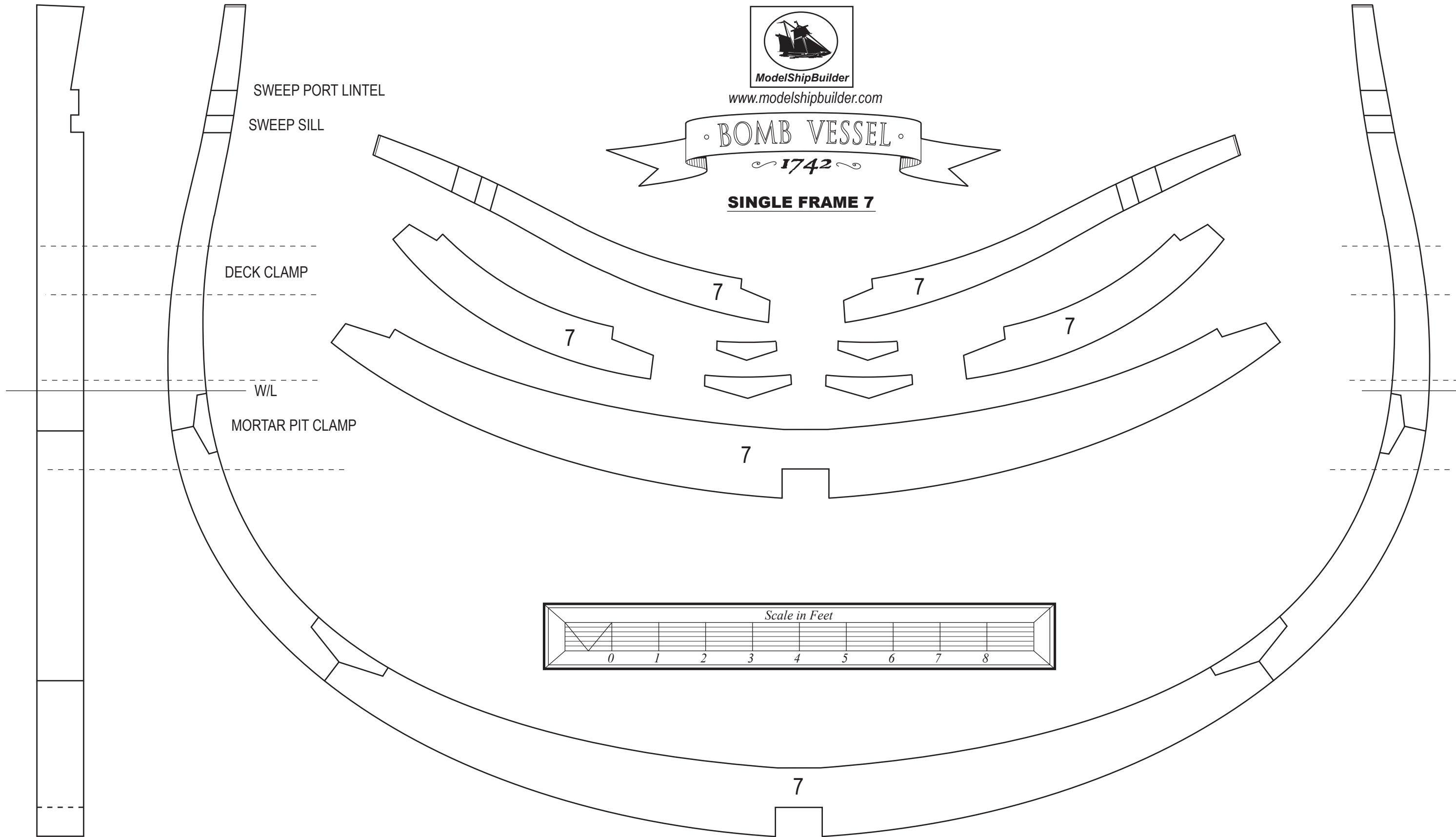

8A



ModelShipBuilder  
www.modelshipbuilder.com



**DOUBLE FRAME 8A**

DECK CLAMP

W/L

MORTAR PIT CLAMP

8A

8A

8A

8A

8A

Scale in Feet

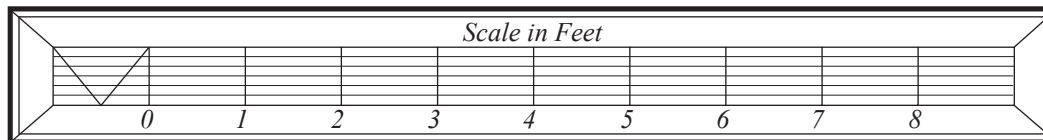

8A

8B



www.modelshipbuilder.com



**DOUBLE FRAME 8B**

SWEEP PORT LINTEL

SWEEP SILL

DECK CLAMP

W/L

MORTAR PIT CLAMP

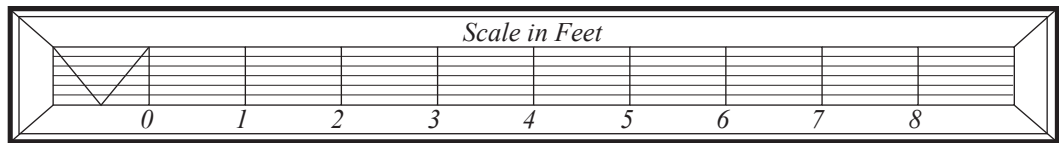
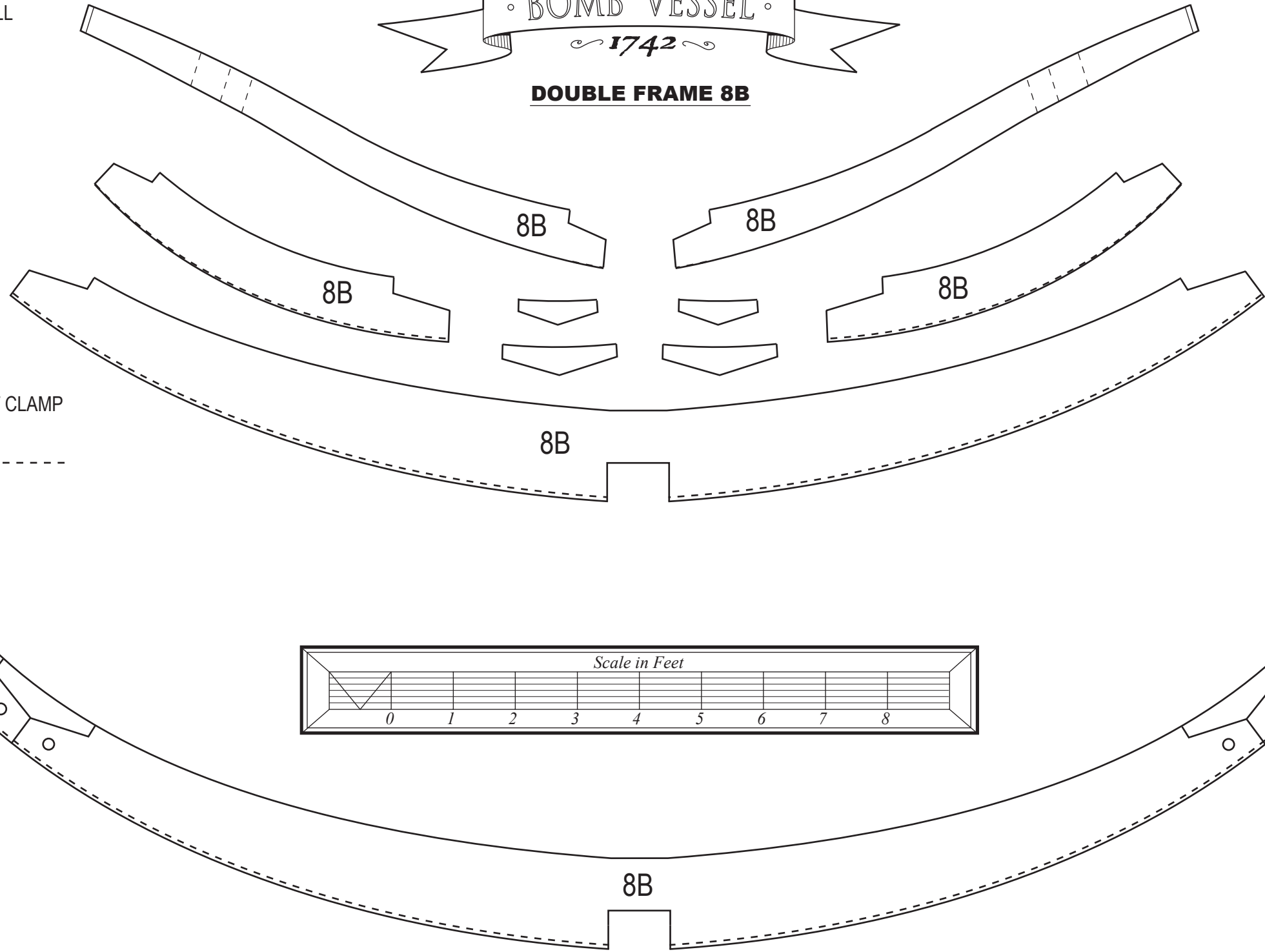



ModelShipBuilder

www.modelshipbuilder.com



**SINGLE FRAME 9**

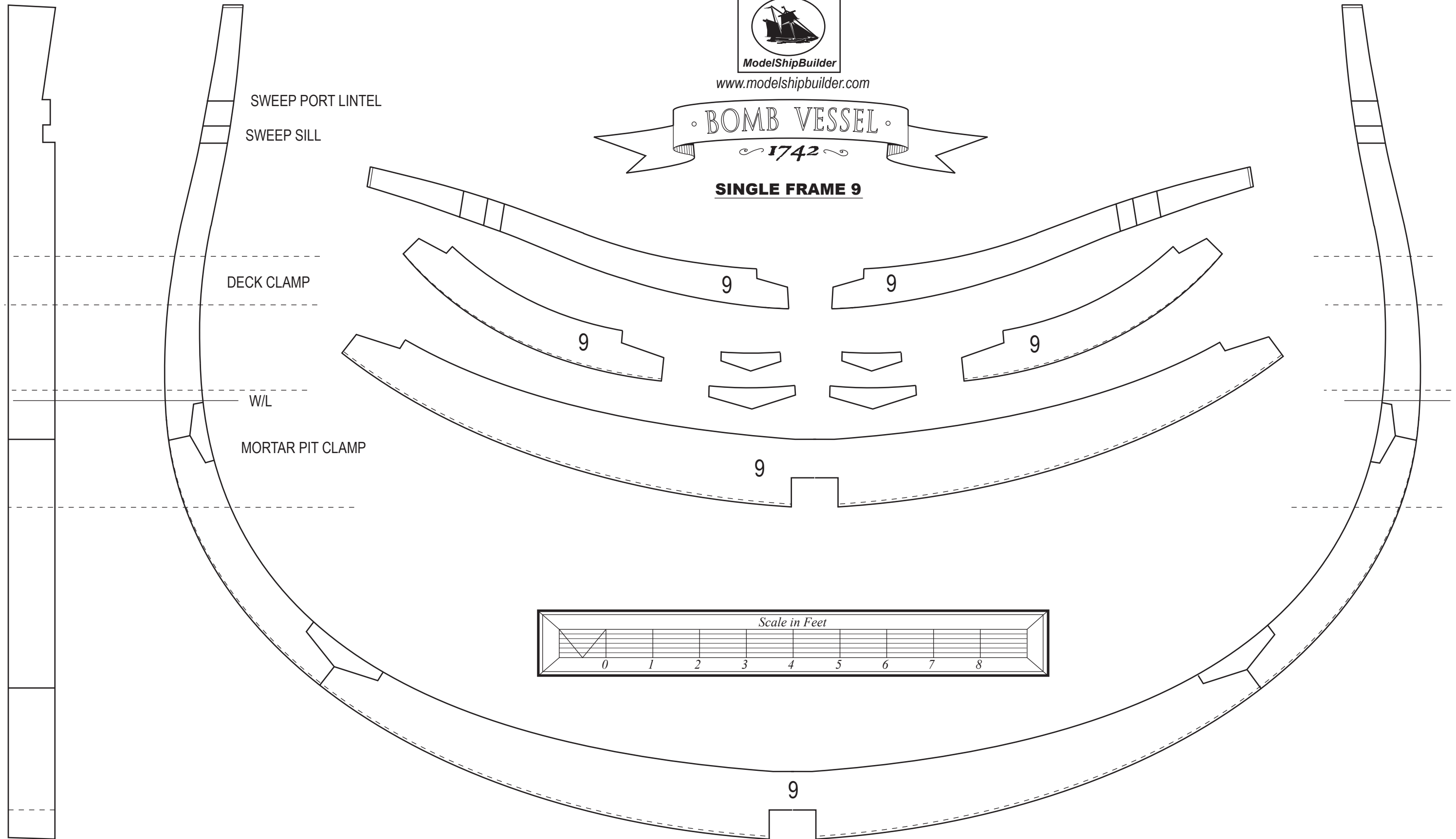



ModelShipBuilder

www.modelshipbuilder.com



**SINGLE FRAME 10**

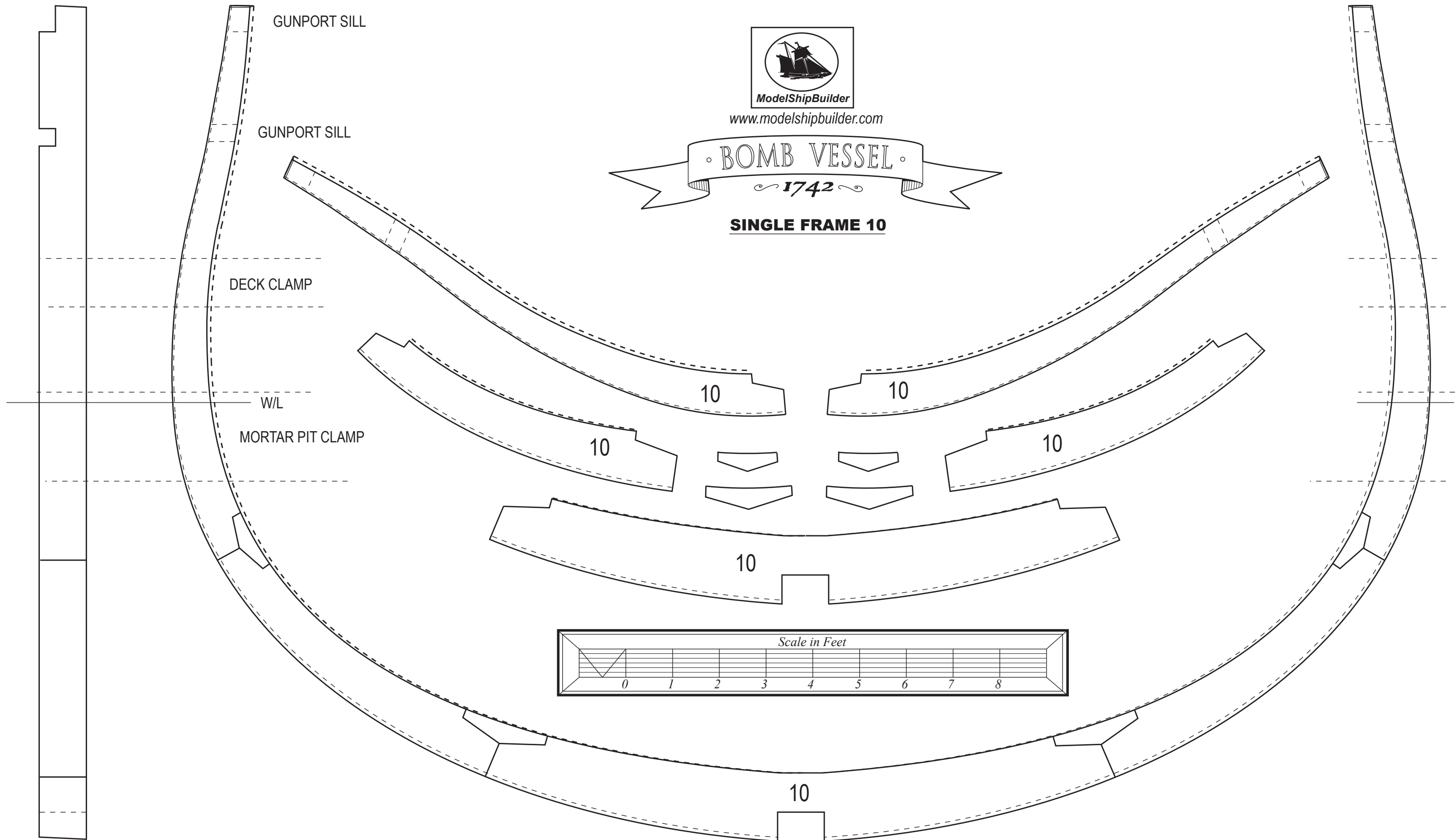



www.modelshipbuilder.com

• BOMB VESSEL •  
1742

**SINGLE FRAME 11**

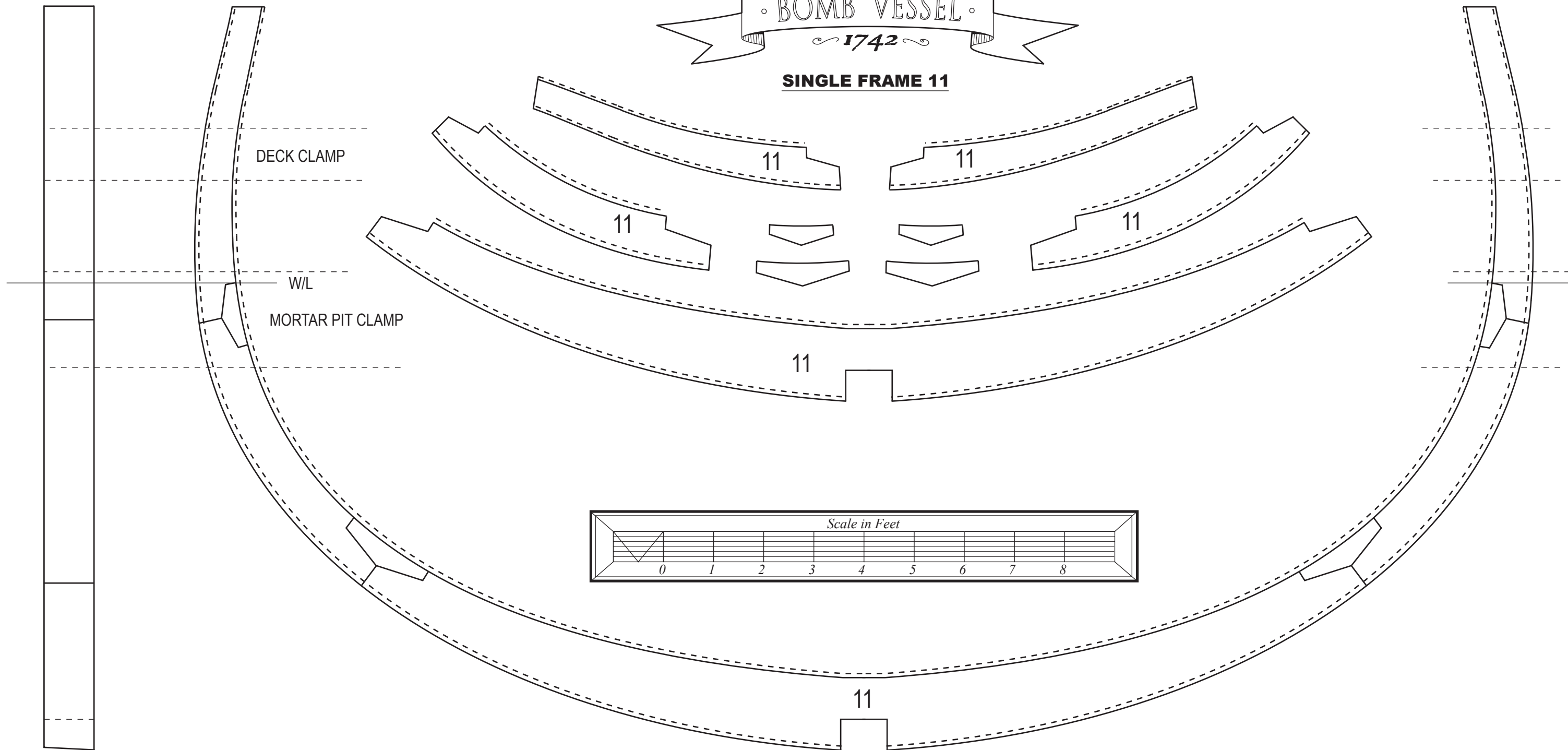

12A



www.modelshipbuilder.com



**DOUBLE FRAME 12A**

GUNPORT SILL

GUNPORT SILL

DECK CLAMP

W/L

MORTAR PIT CLAMP

12A

12A

12A

12A

12A

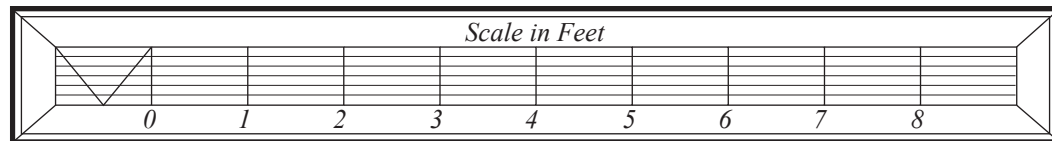

12A



www.modelshipbuilder.com



**DOUBLE FRAME 12B**

12B

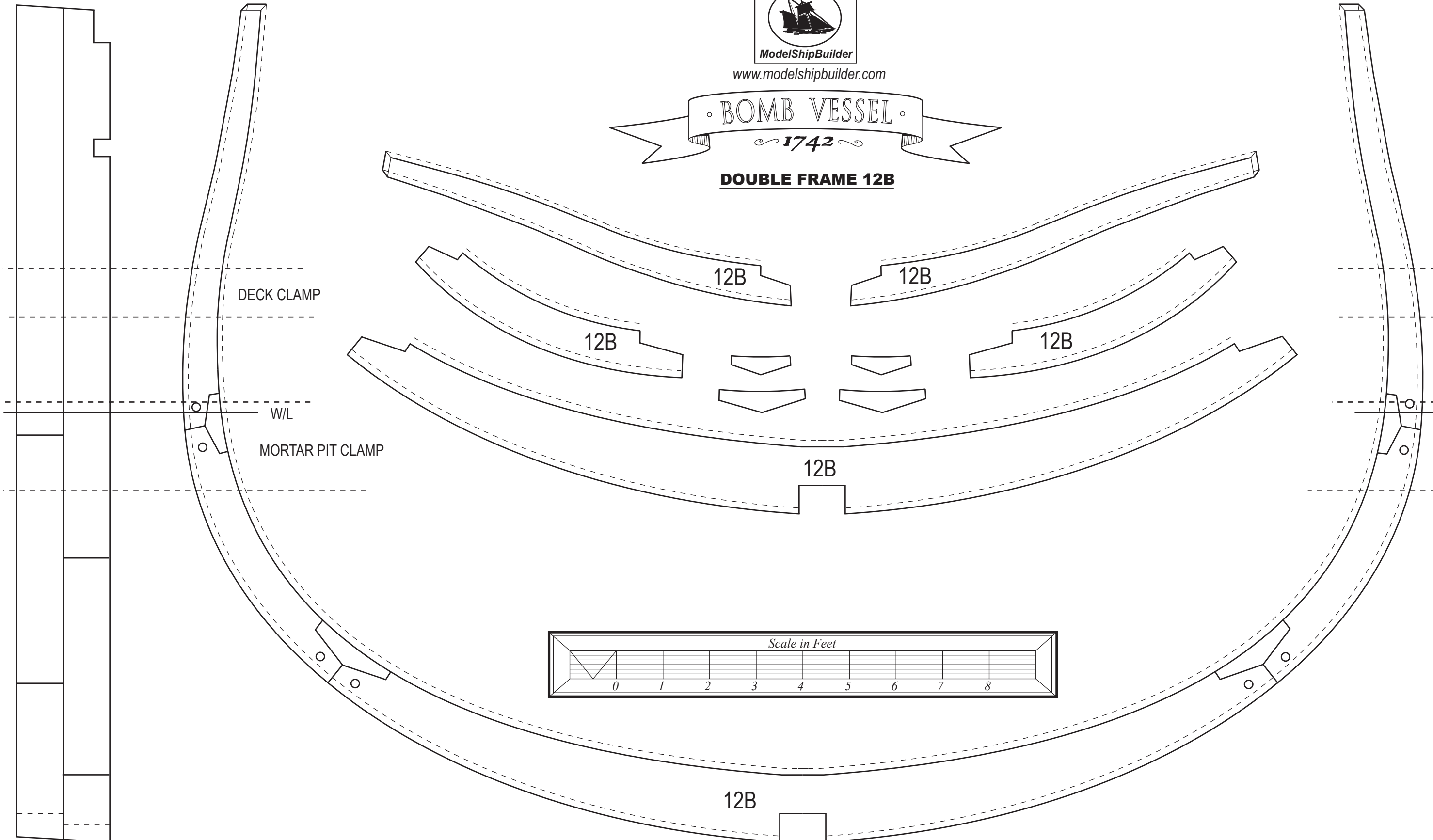

DECK CLAMP

W/L

MORTAR PIT CLAMP

12B

12B

12B

12B

12B

12B

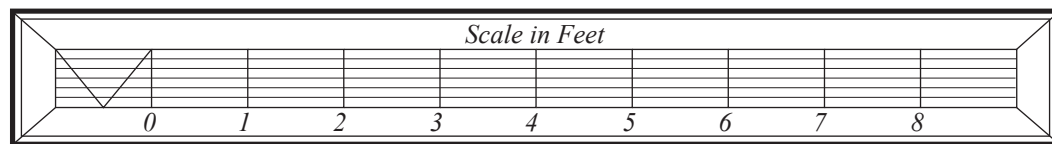



ModelShipBuilder

[www.modelshipbuilder.com](http://www.modelshipbuilder.com)



**FRAMING JIG TEMPLATE**

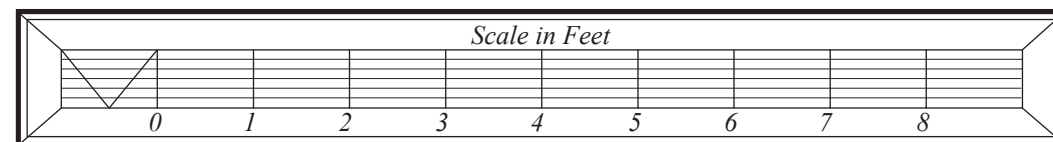

12

11

10

9

8

7

6

5

4

3

2

1

Ø

A

B

C

D

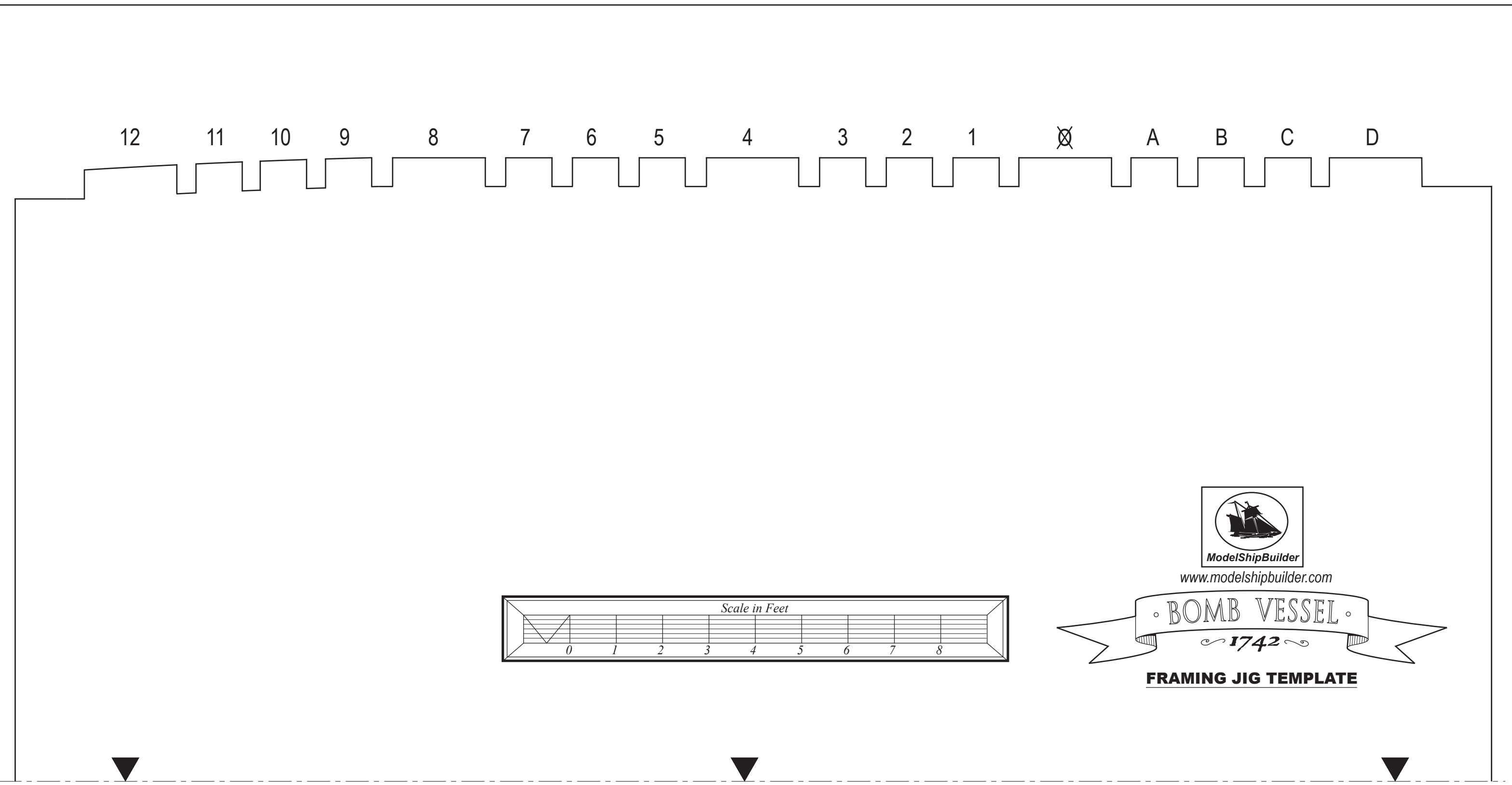

12

11

10

9

8

7

6

5

4

3

2

1

⊗

A

B

C

D

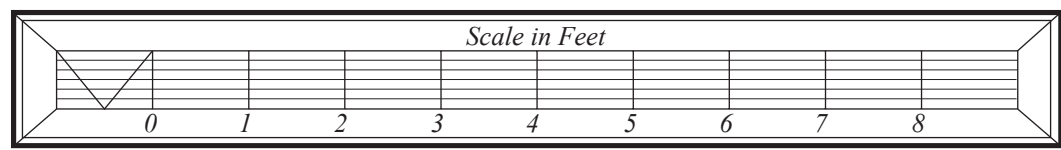

ModelShipBuilder

[www.modelshipbuilder.com](http://www.modelshipbuilder.com)

◦ BOMB VESSEL ◦

1742

**FRAMING JIG TEMPLATE**



ModelShipBuilder  
www.modelshipbuilder.com



**FRAMING JIG TEMPLATE**

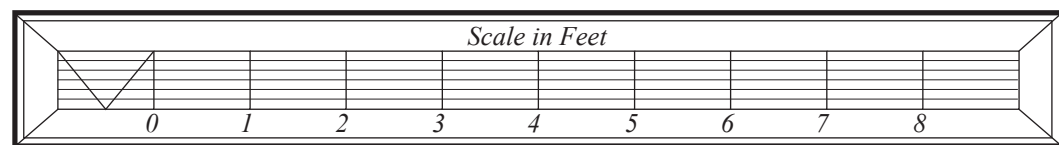
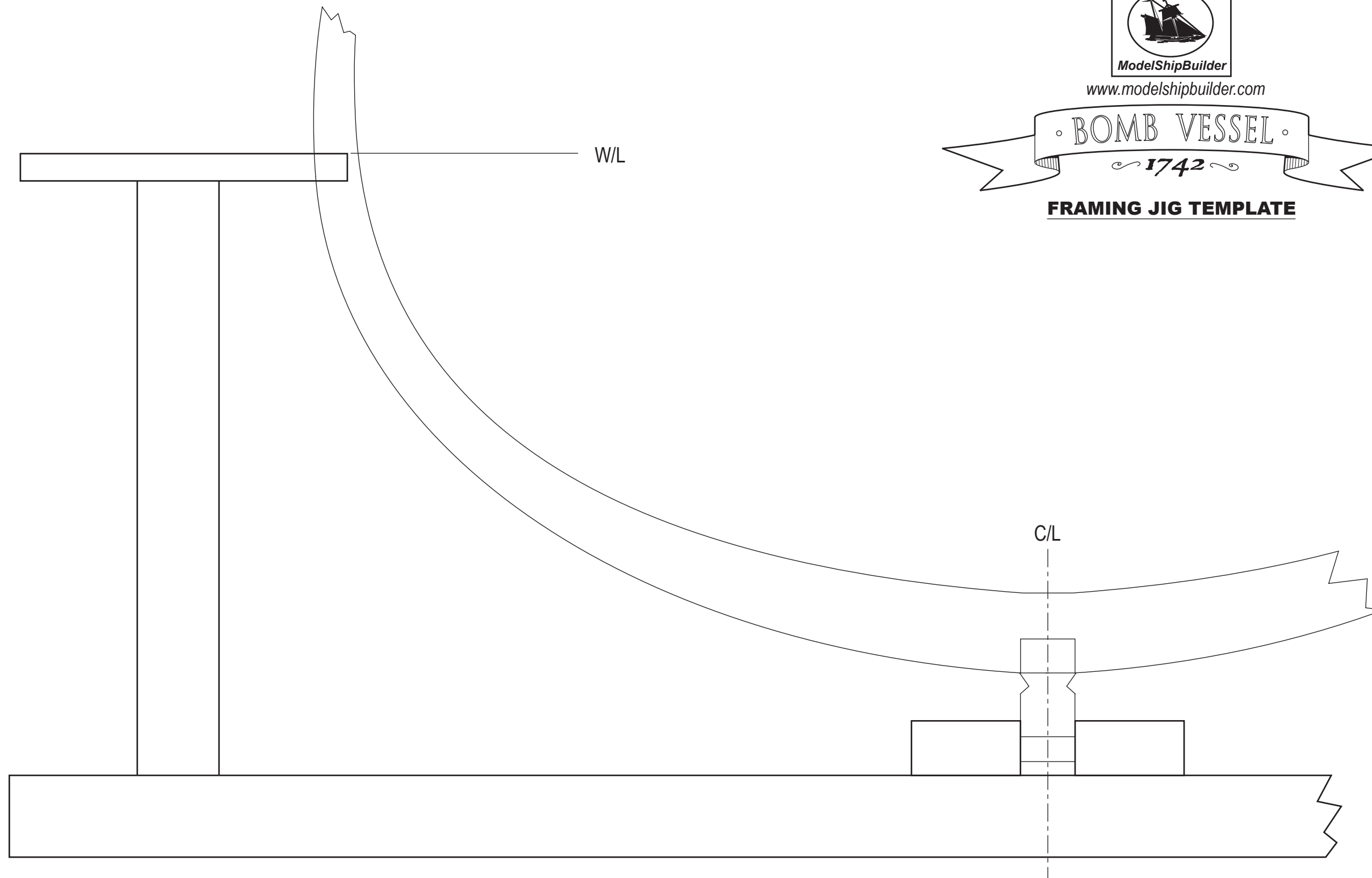

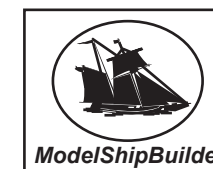
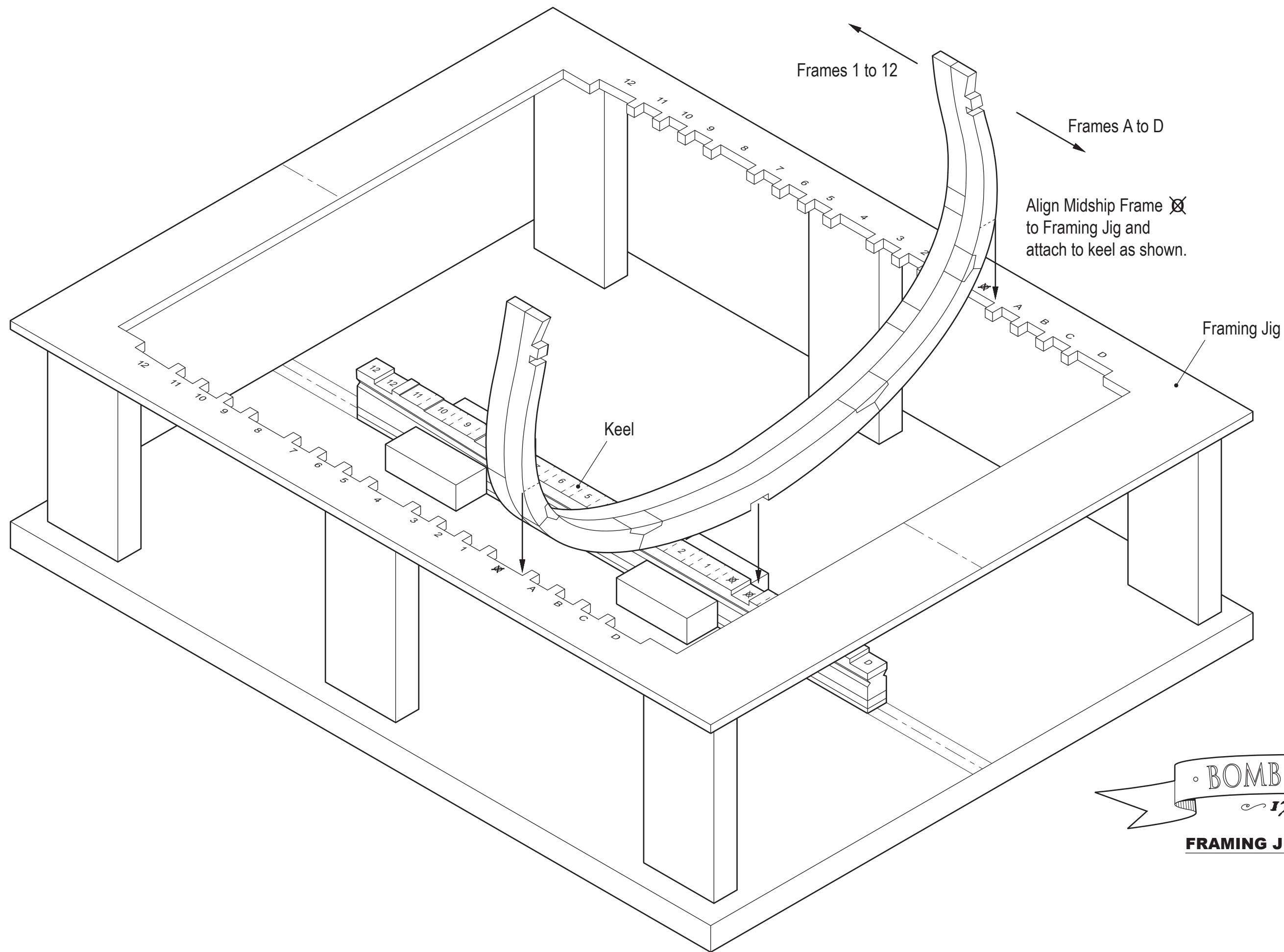

ModelShipBuilder  
www.modelshipbuilder.com



**FRAMING JIG ASSEMBLY**



www.modelshipbuilder.com



### GUNPORT & SWEEP SILLS

- 1. Gunport Sill
- 2. Sweep Sill
- 3. Filling Lintel
- 4. Sweep Port
- 5. Gunport

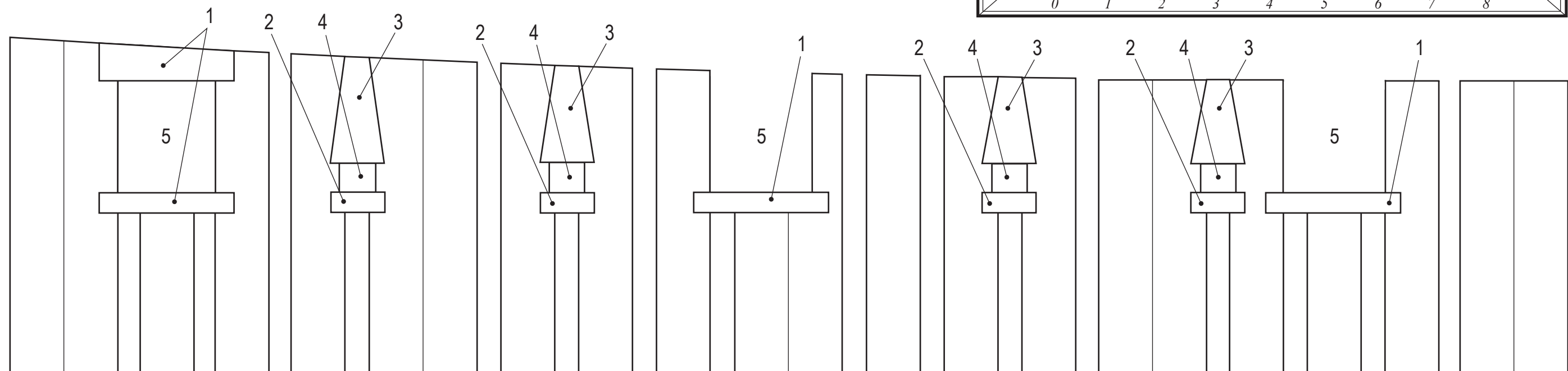
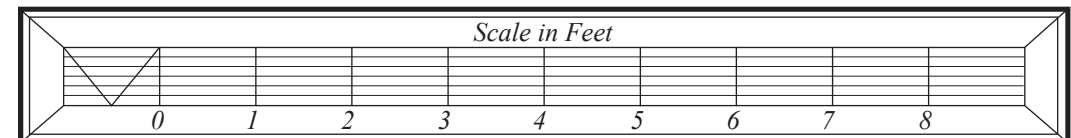
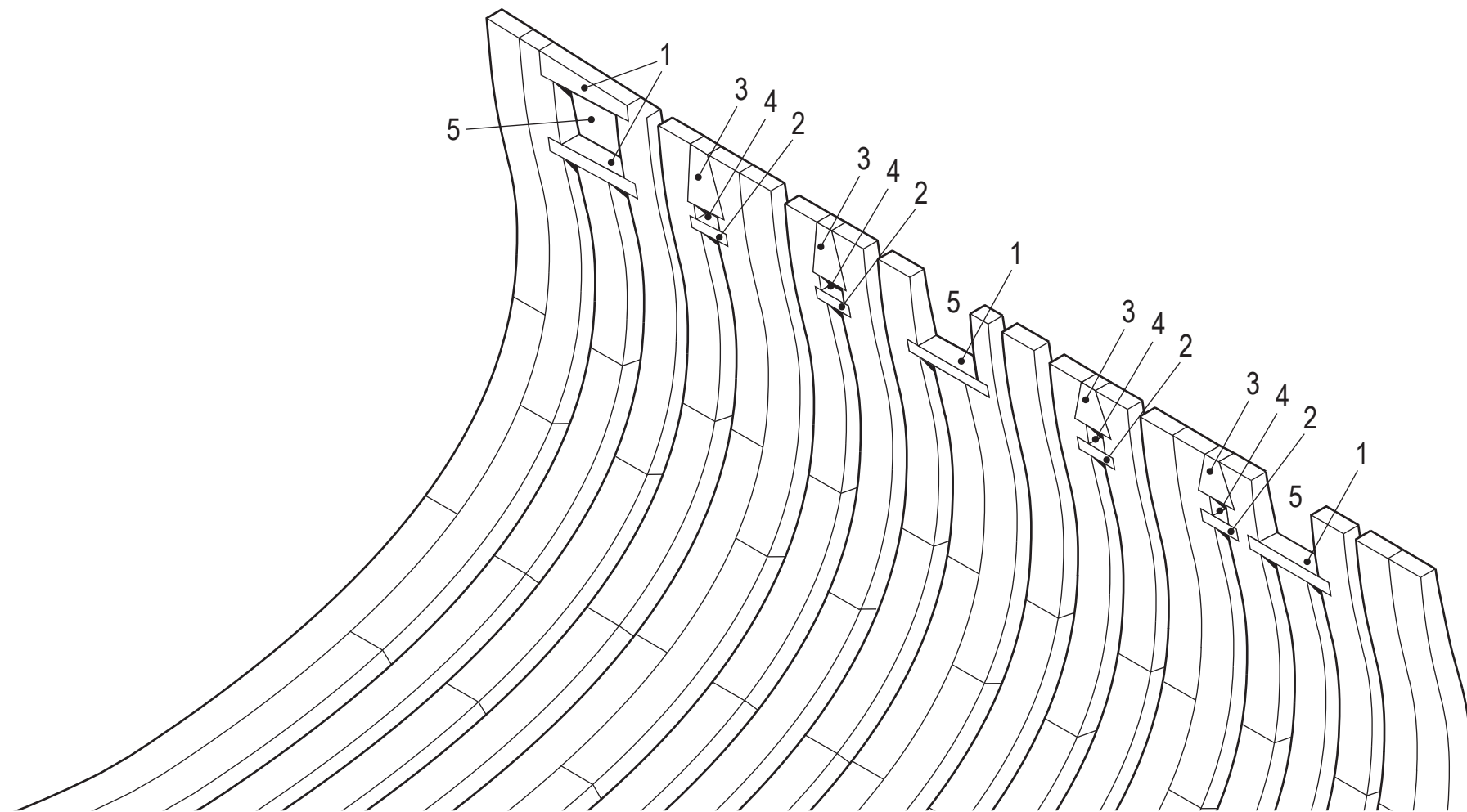

**KEELSON & DECK CLAMPS**

1. Keelson
2. Mortar Pit Deck Clamp (Lower Strake)
3. Mortar Pit Deck Clamp (Upper Strake)
4. Upper Deck Clamp (Lower Strake)
5. Upper Deck Clamp (Upper Strake)

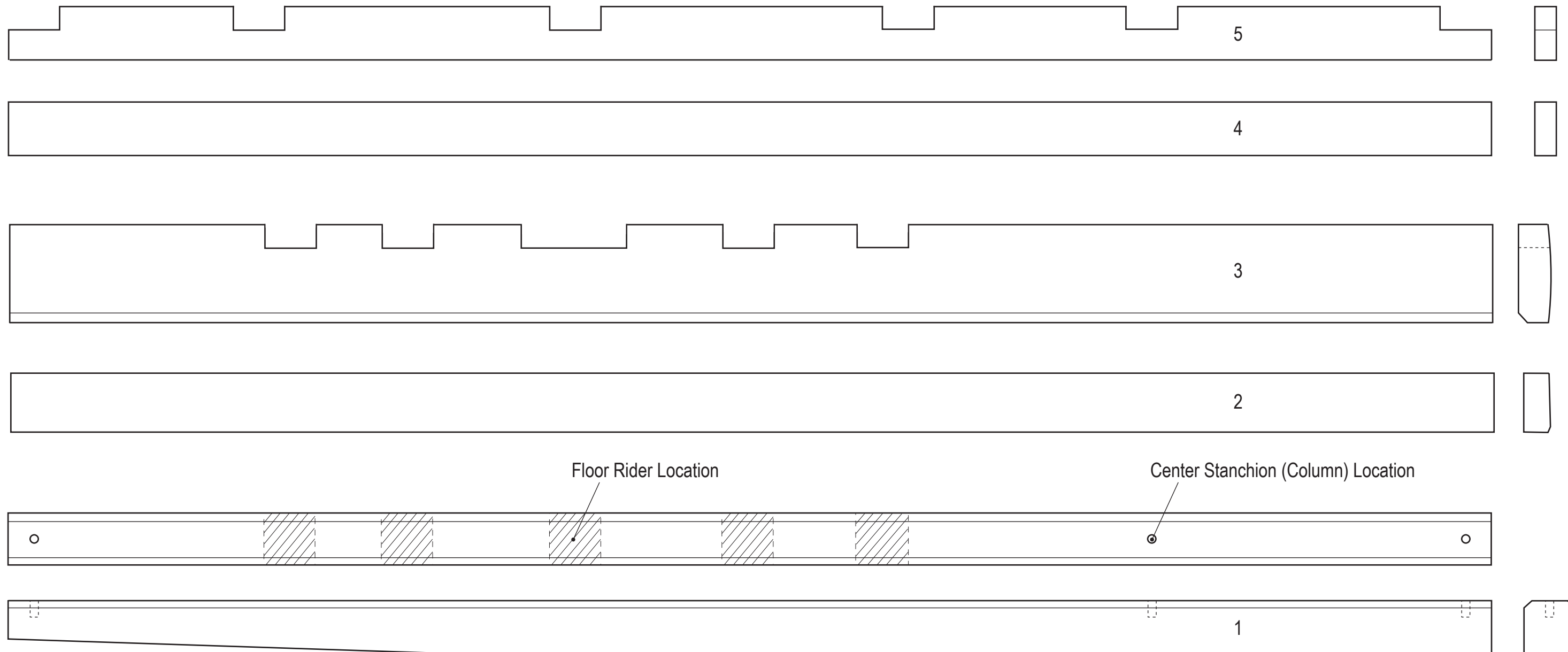
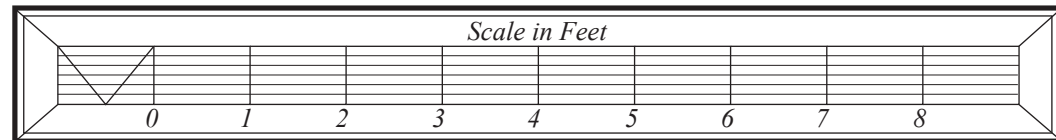



www.modelshipbuilder.com

# BOMB VESSEL

1742

## FLOOR RIDERS

- 1. Futtock Rider
- 2. Floor Rider

Align Floor Riders and Deck Clamp as shown.

Mortar Deck Clamp

Thickstuff - Upper Strake

Keelson

Align Floor Riders to location marked on top of Keelson.

Keelson (Not to Scale)

**NOTE**  
Framing details removed for clarity.

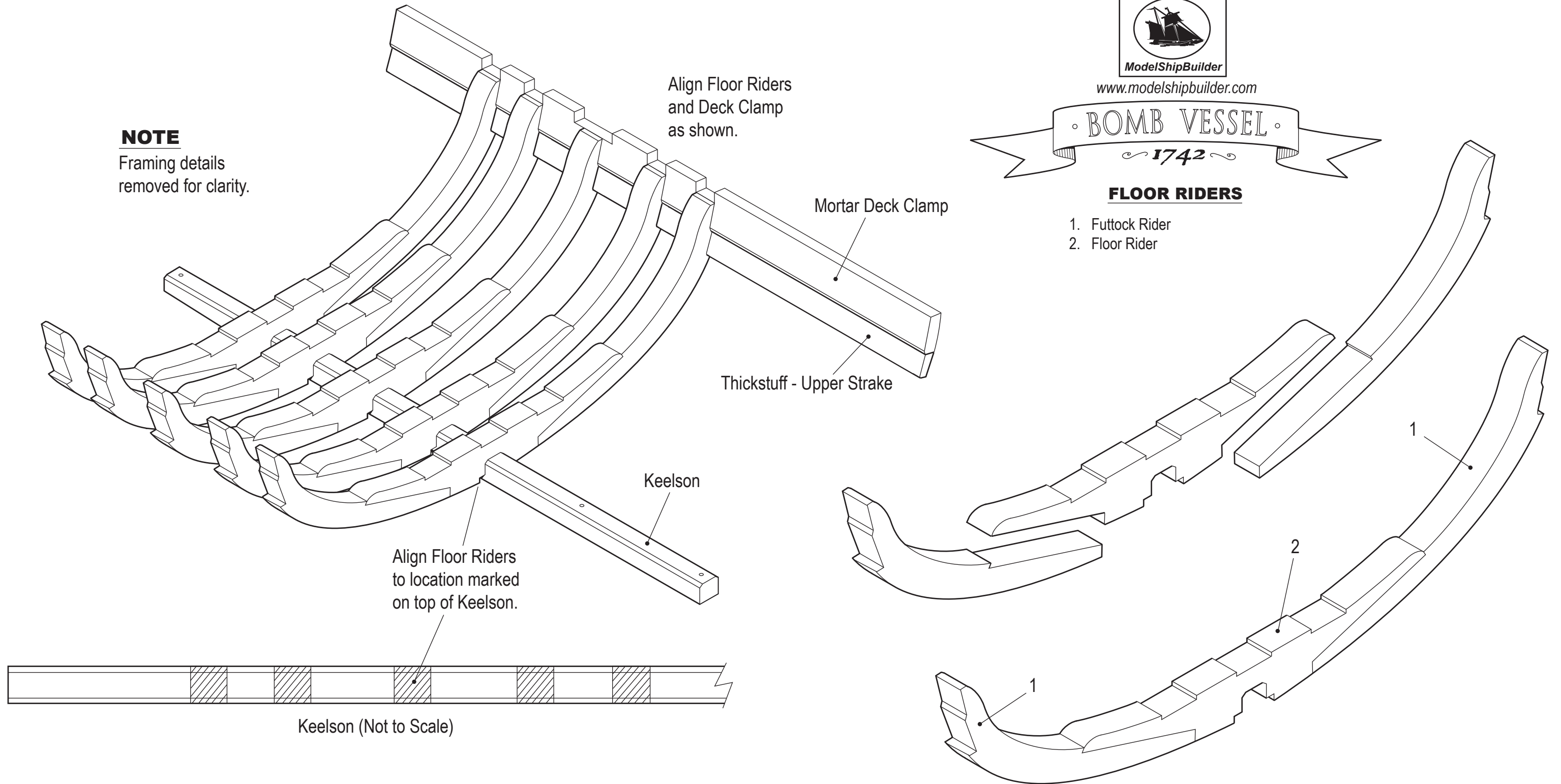

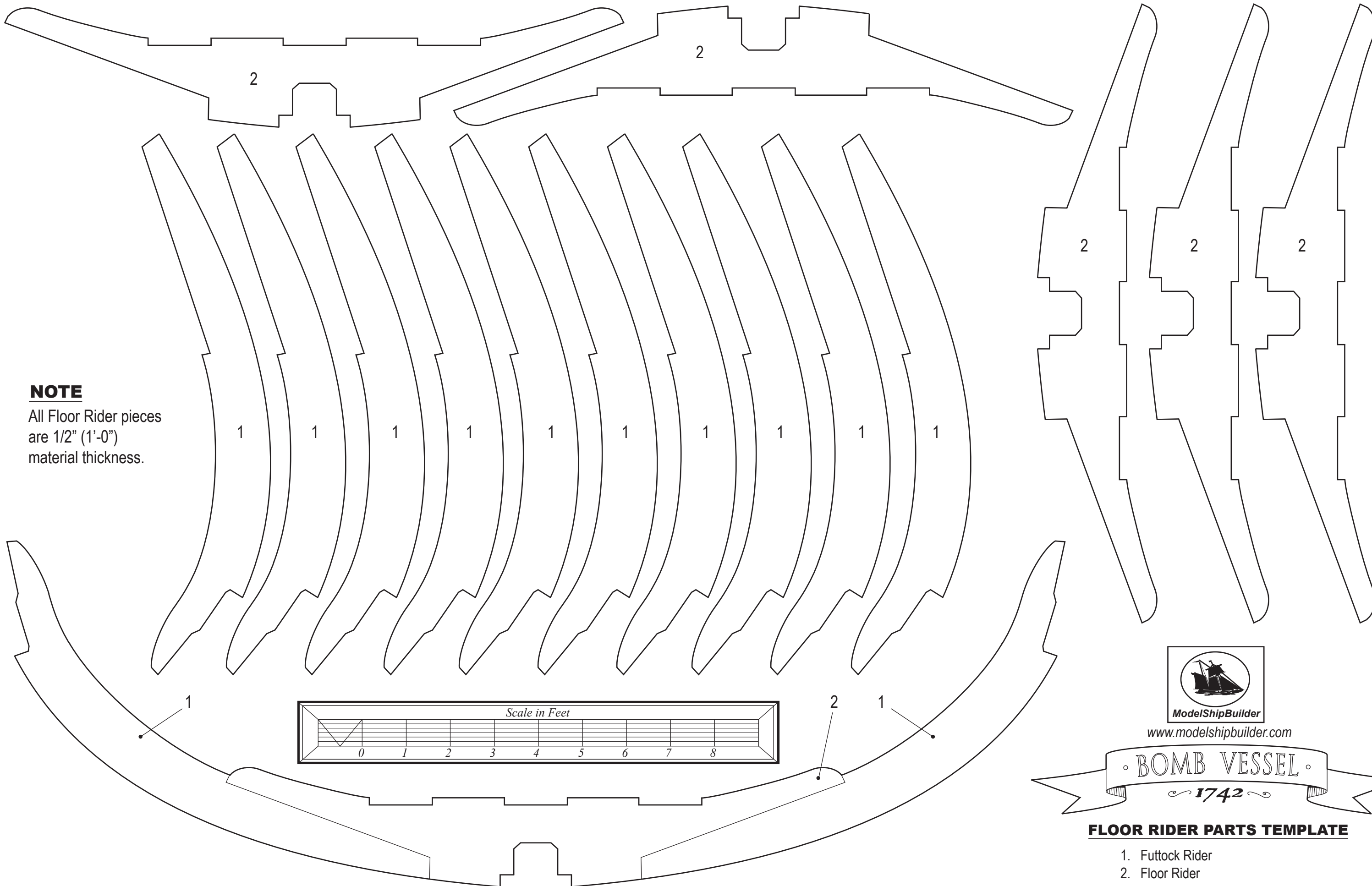

**NOTE**

All Floor Rider pieces are 1/2" (1'-0") material thickness.

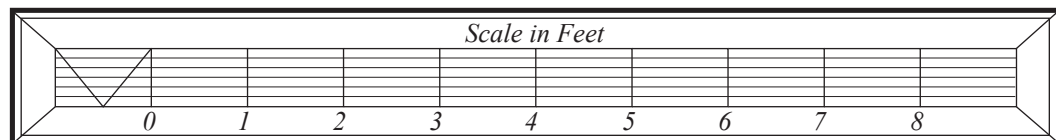

www.modelshipbuilder.com

◦ BOMB VESSEL ◦  
1742

**FLOOR RIDER PARTS TEMPLATE**

- 1. Futtock Rider
- 2. Floor Rider



www.modelshipbuilder.com

# BOMB VESSEL 1742

## LIMBER BOARD & STRAKE

- 1. Limber Board
- 2. Limber Strake
- 3. Footwaling

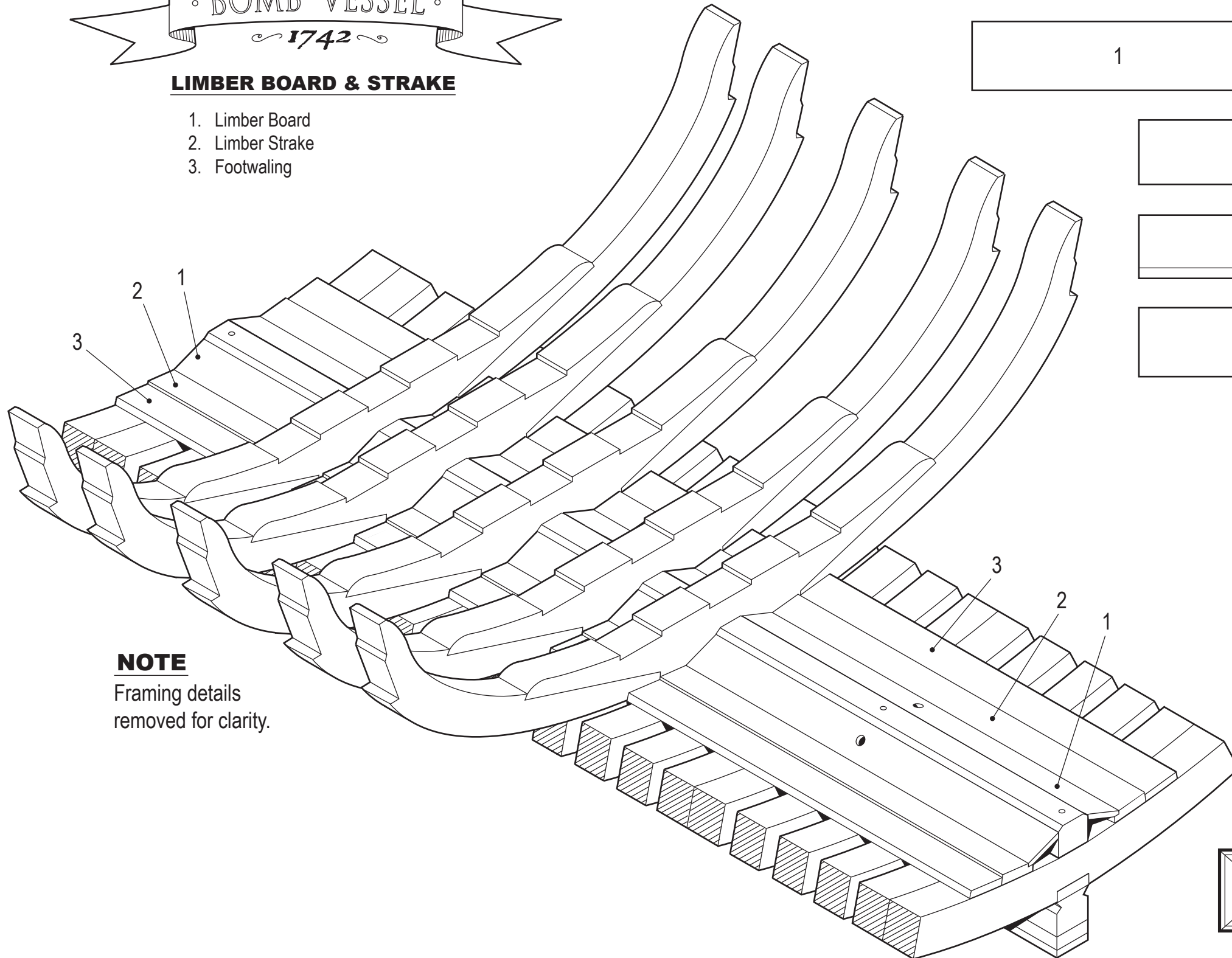

**NOTE**  
Framing details removed for clarity.

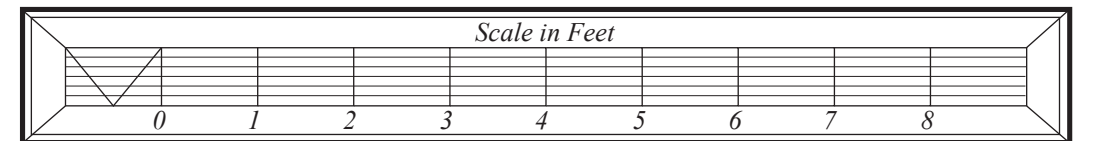
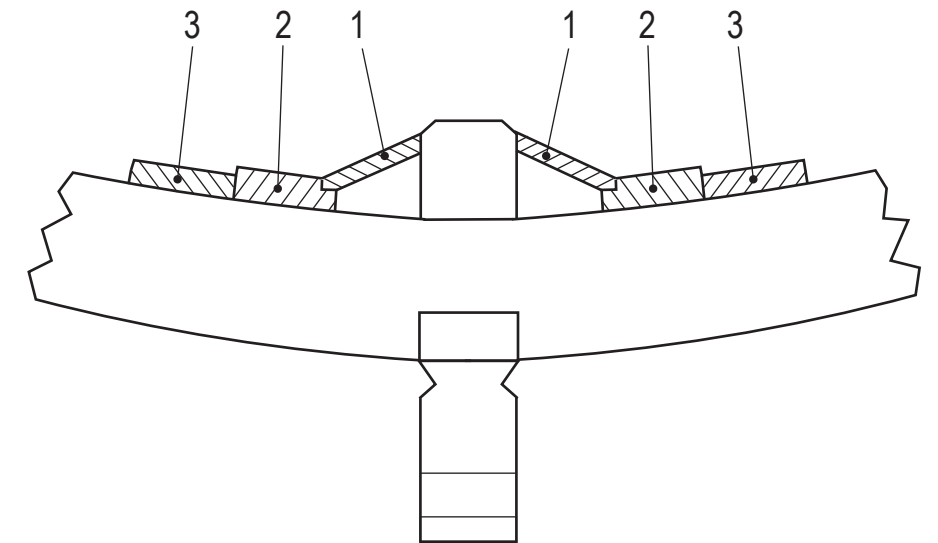
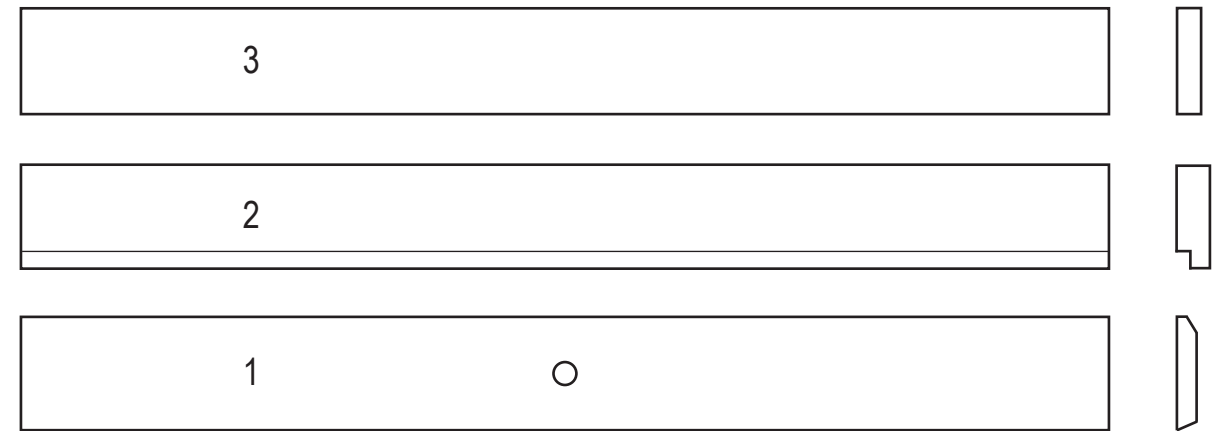
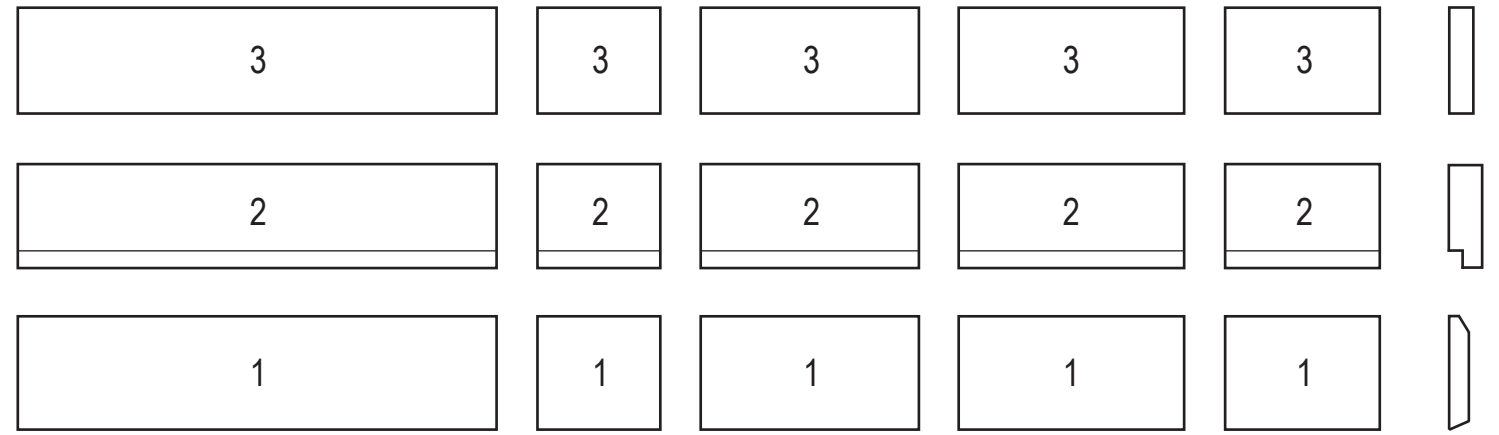



www.modelshipbuilder.com

# BOMB VESSEL

1742

## FOOTWAILING STRAKE

- 1. Upper Footwailing Strake
- 2. Thickstuff
- 3. Lower Footwailing Strake

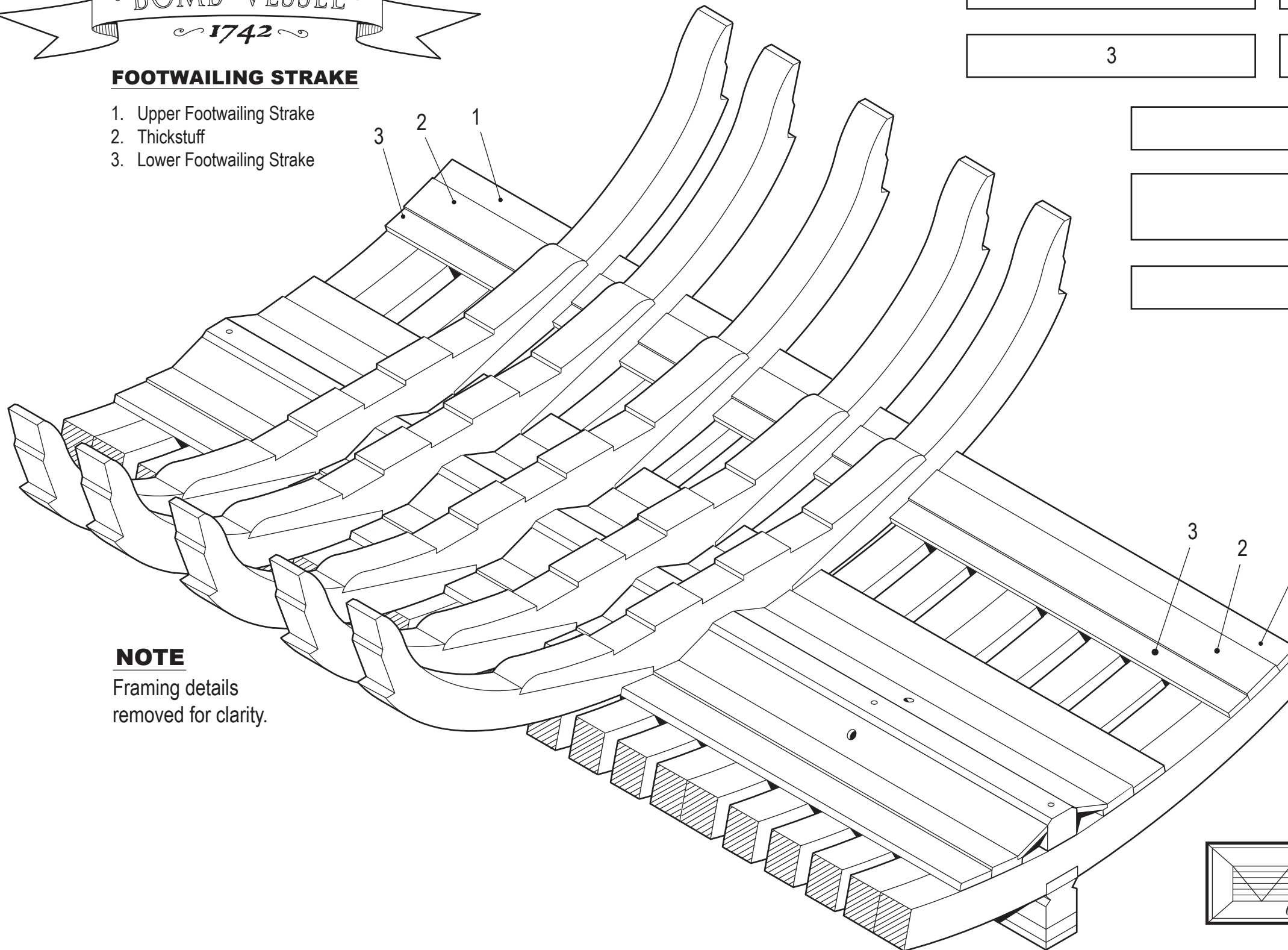

**NOTE**  
Framing details  
removed for clarity.

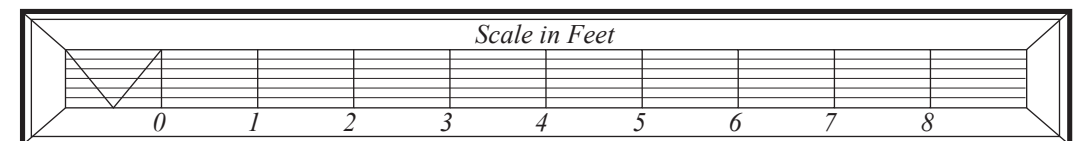
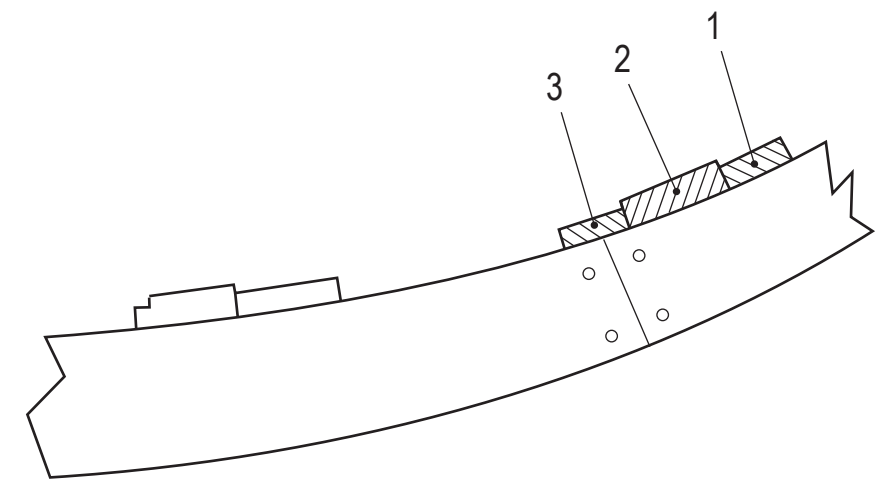
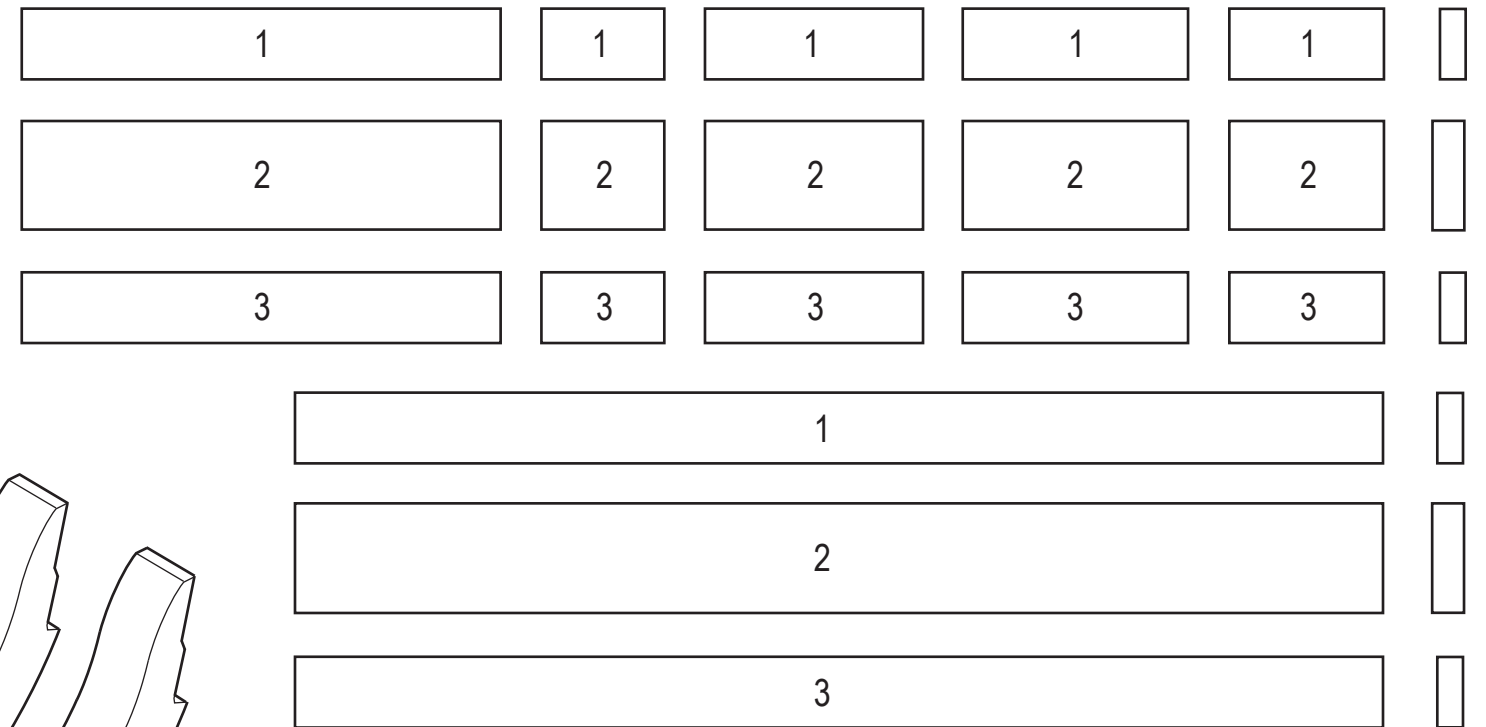



ModelShipBuilder

www.modelshipbuilder.com

# BOMB VESSEL

1742

## SHELL ROOM

- 1. Support Beam (Lower)
- 2. Shell Room Deck Beam
- 3. Shell Room Deck
- 4. Support Beam (Upper)
- 5. Filling Timber
- 6. Pillar
- 7. Shell Rack
- 8. Shell

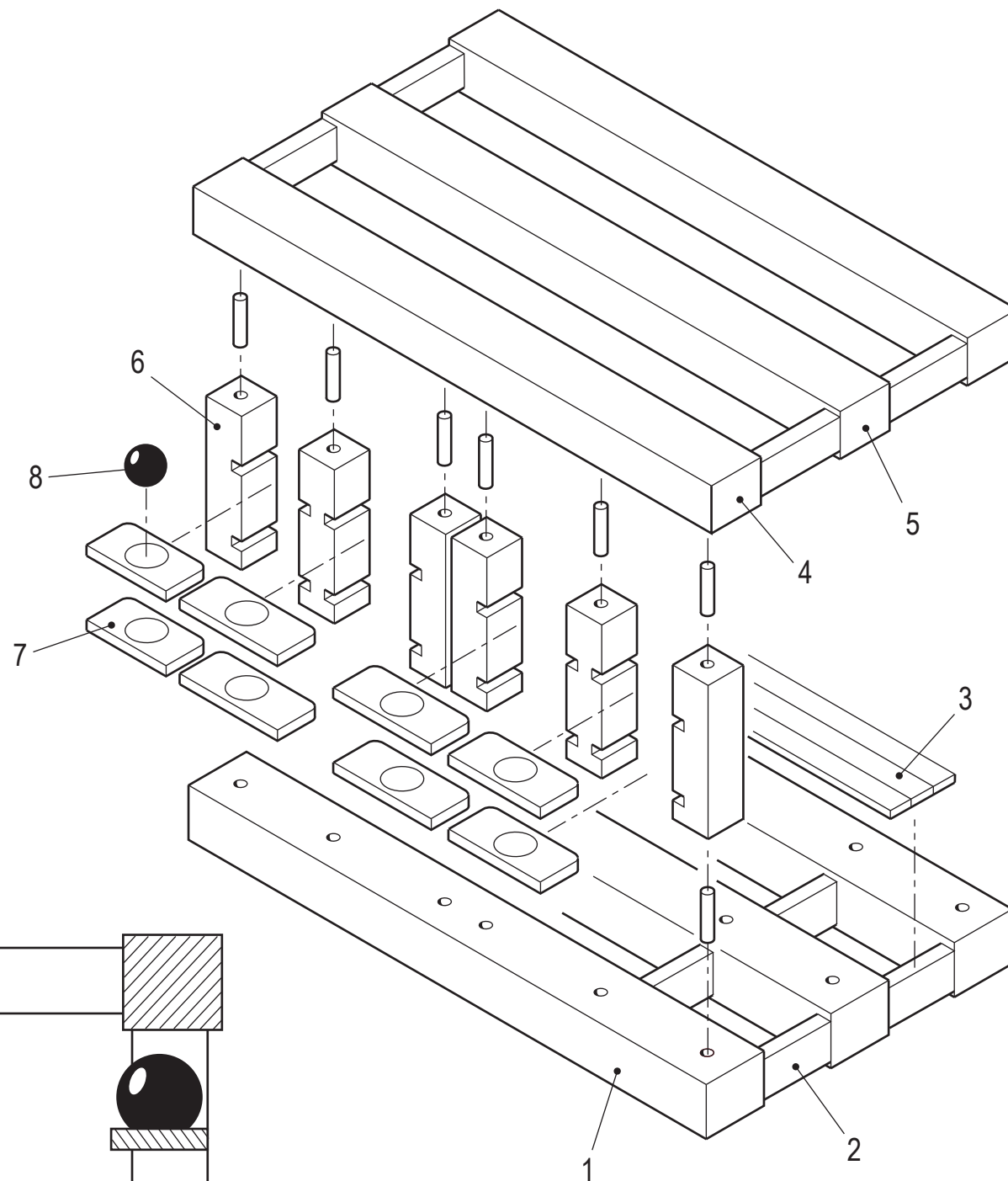
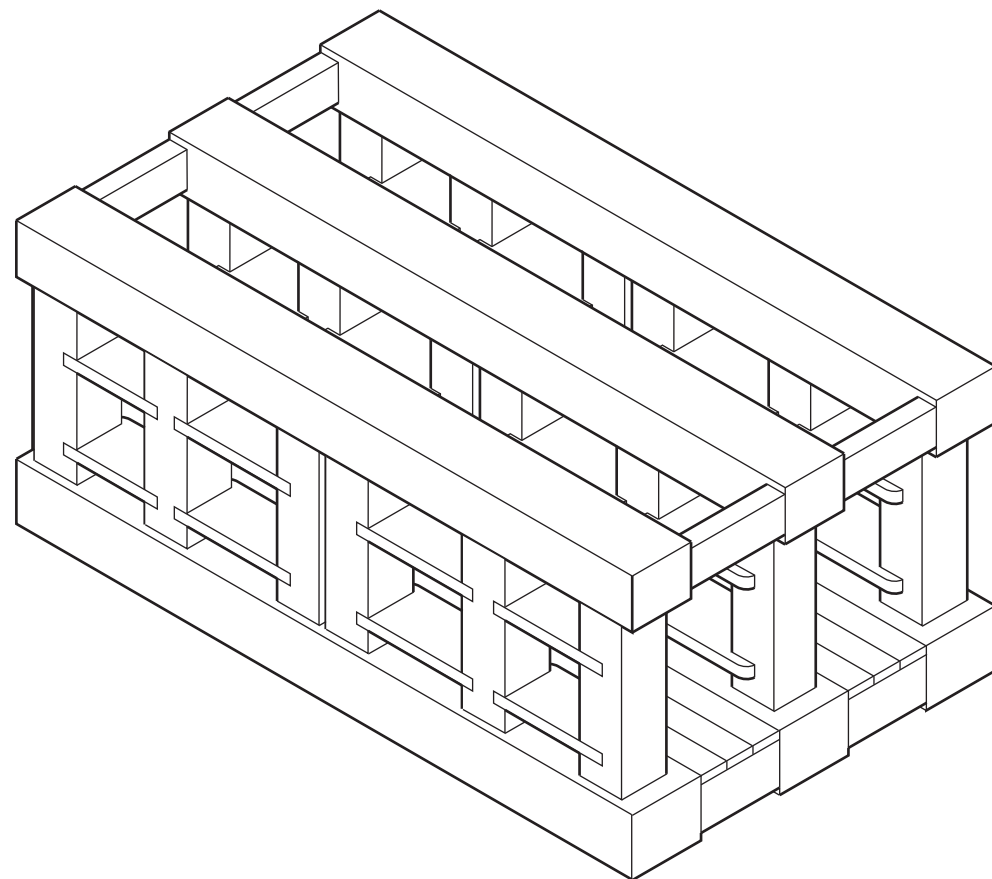

Mortar Pit Deck Beam

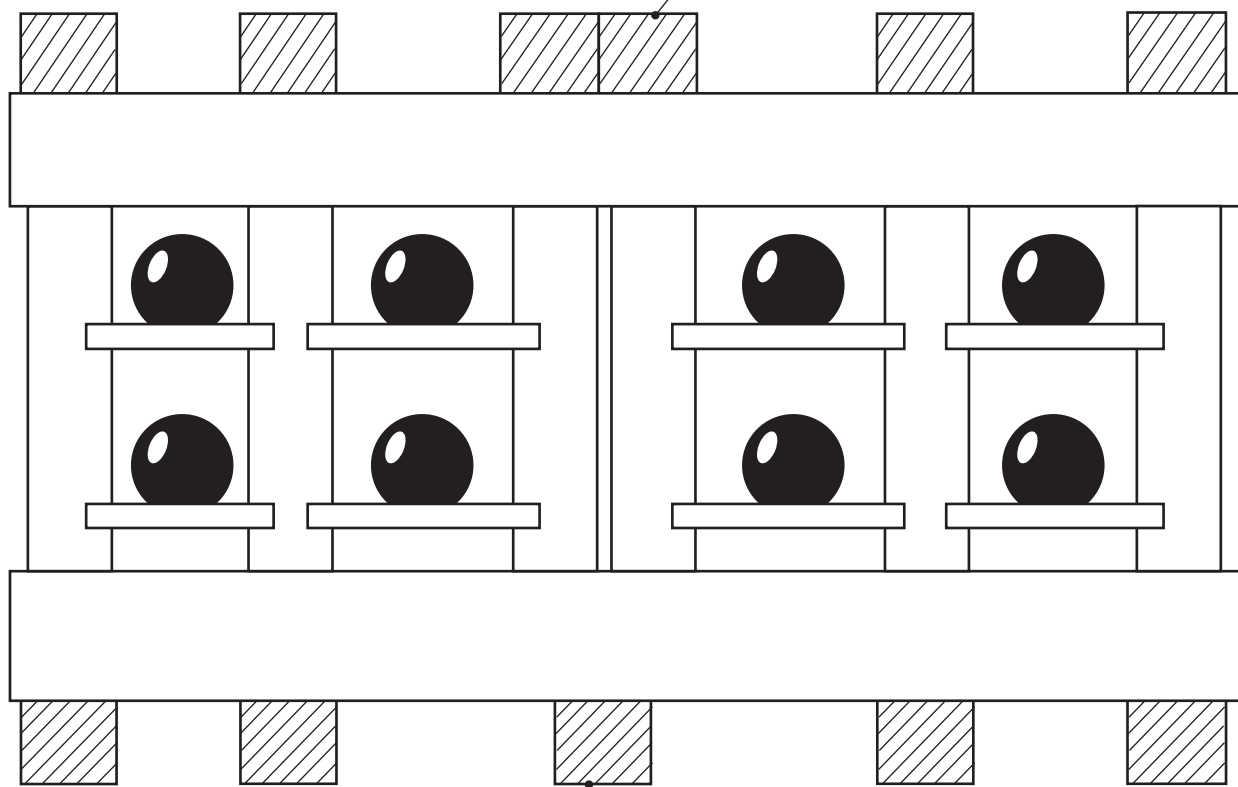

Floor Rider

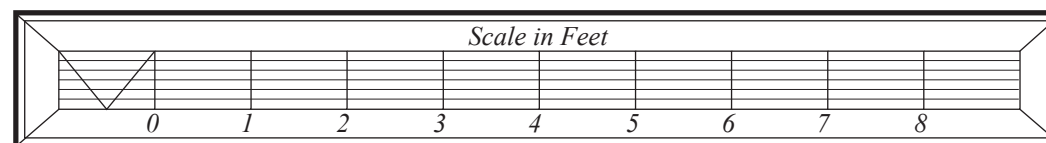
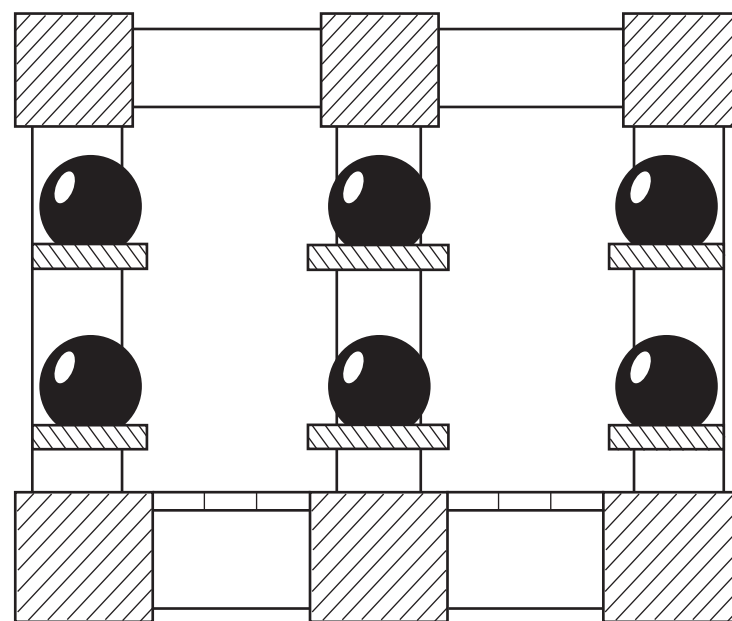



www.modelshipbuilder.com



### SHELL ROOM

- 1. Support Beam (Lower)
- 2. Shell Room Deck Beam
- 3. Shell Room Deck
- 4. Support Beam (Upper)
- 5. Filling Timber
- 6. Pillar
- 7. Shell Rack

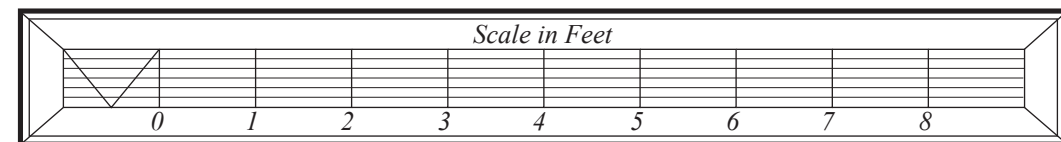
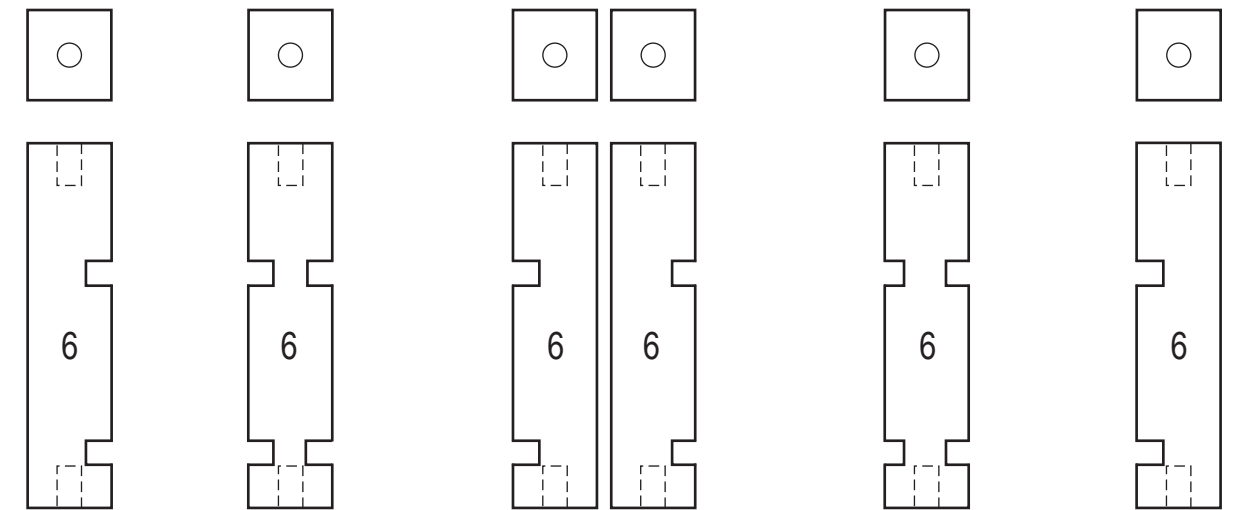
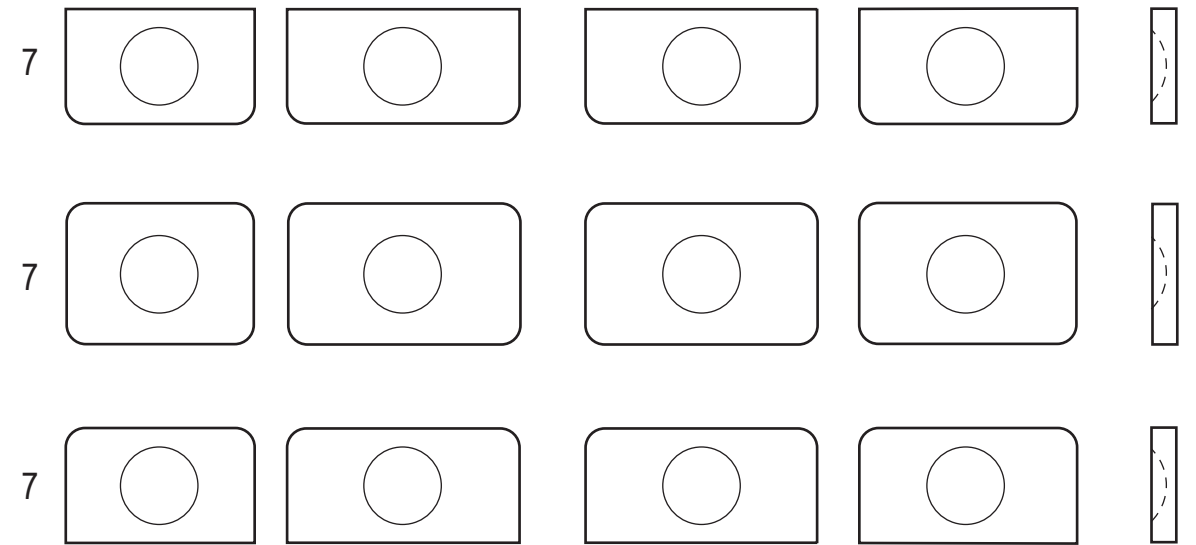
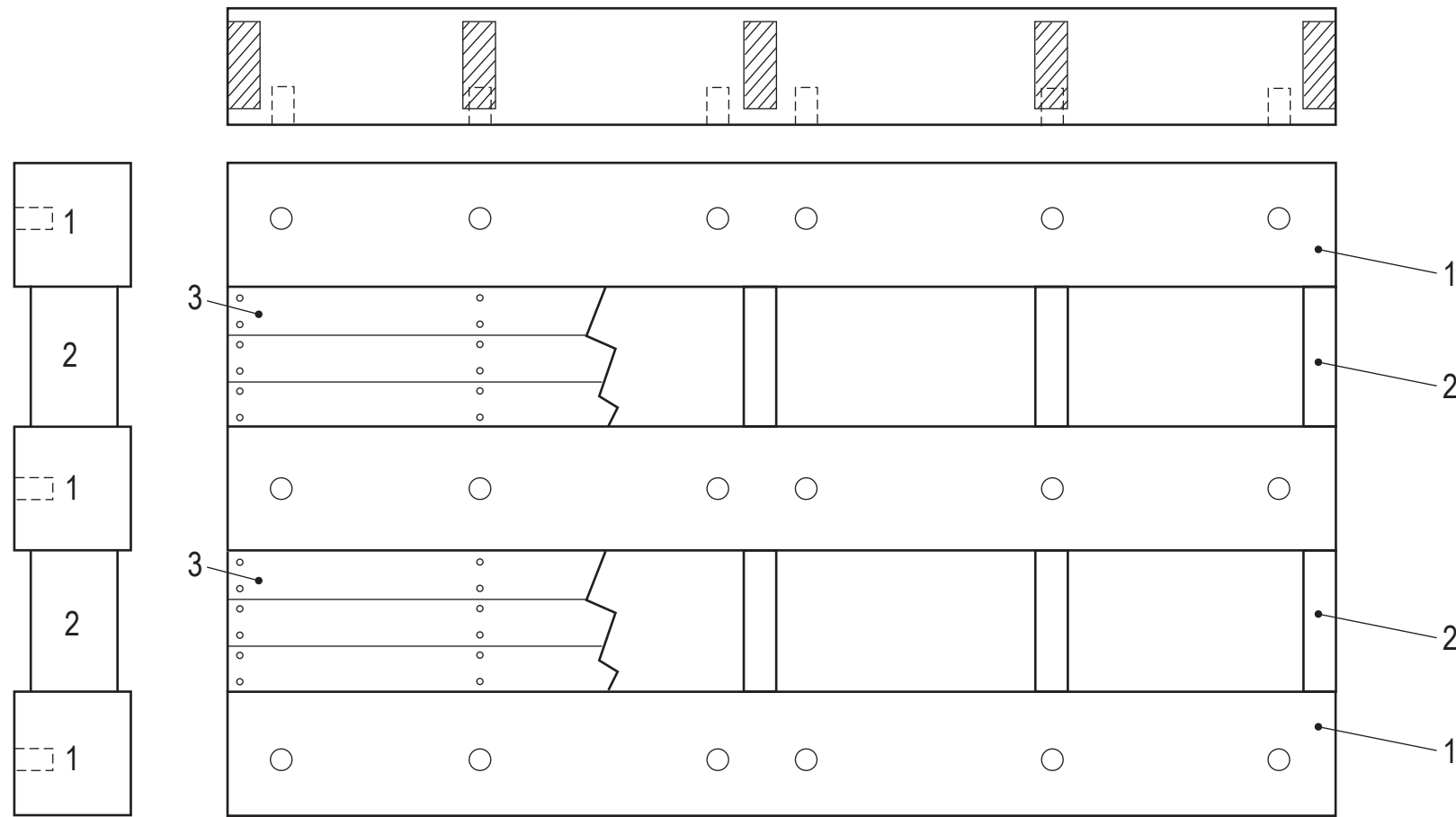



www.modelshipbuilder.com



### MORTAR PIT BEAMS & PLANKING

- 1. Mortar Pit Beam
- 2. Mortar Pit Boundary Timber
- 3. Mortar Pit Primary Planking
- 4. Mortar Pit Secondary Planking

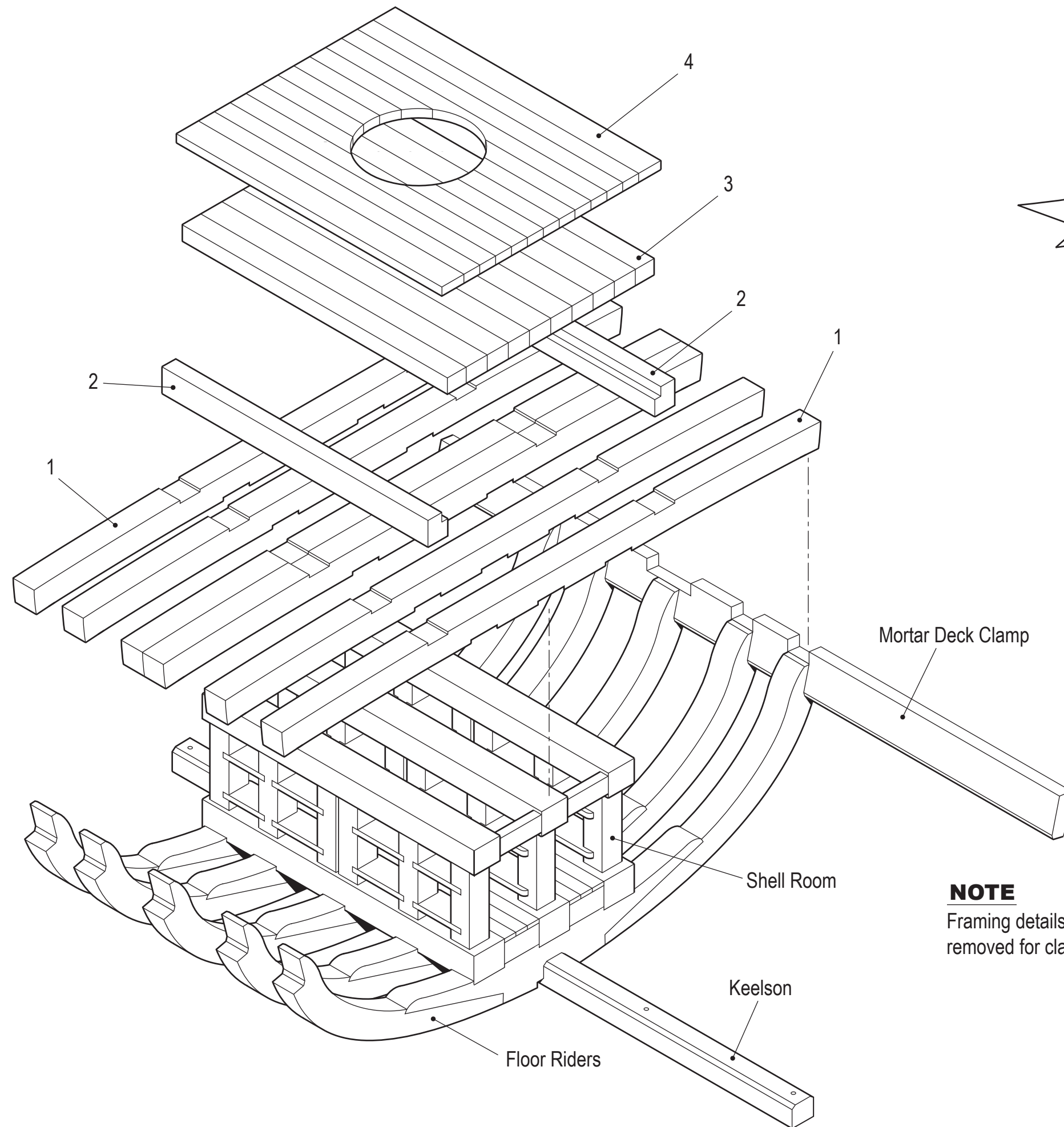

**NOTE**  
Framing details  
removed for clarity.

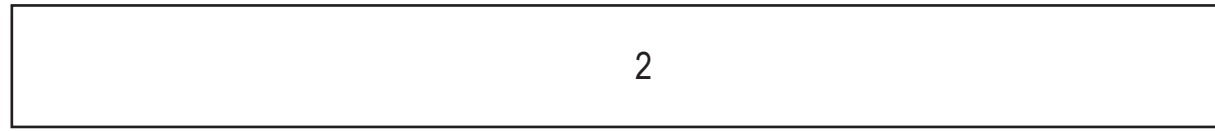
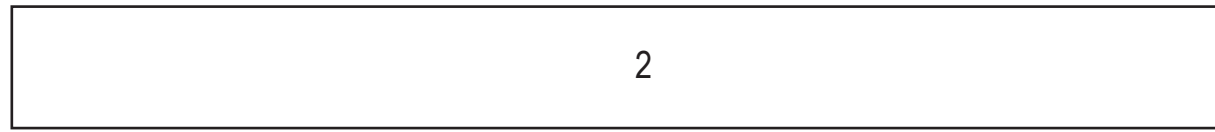

**MORTAR PIT BEAM - PARTS TEMPLATE**

- 1. Mortar Pit Beam
- 2. Mortar Pit Boundary Timber

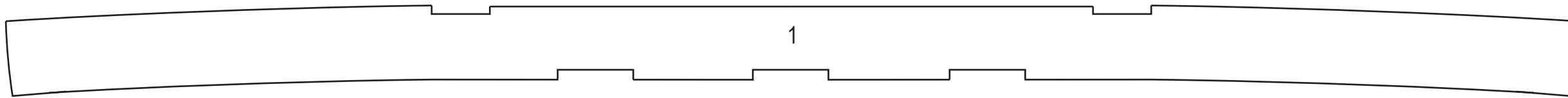

1

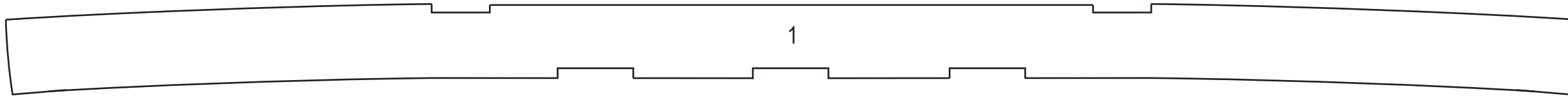

1

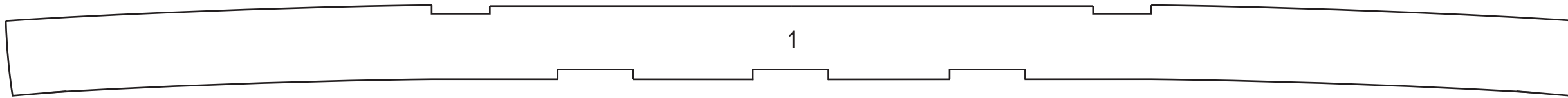

1

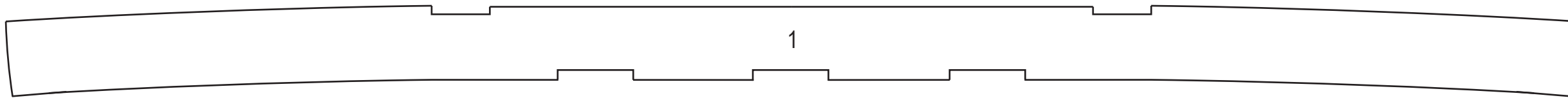

1

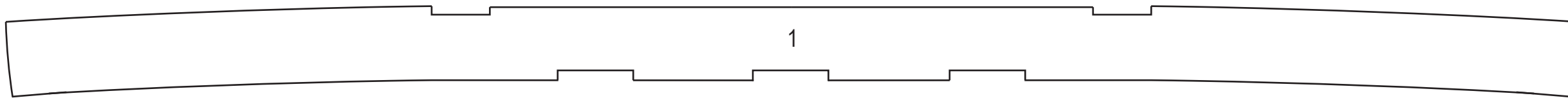

1

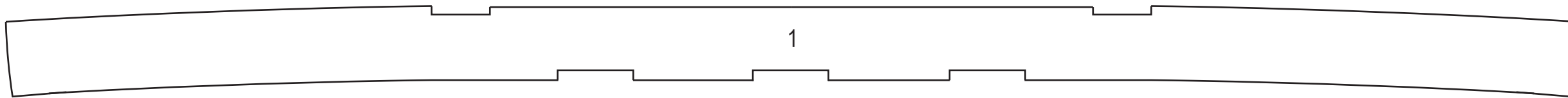

1

**NOTE**

All Beam pieces are 1/2" (1'-0") material thickness.

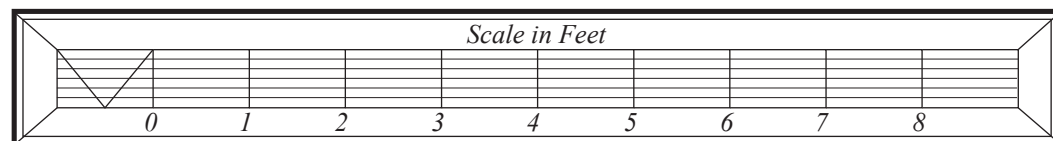



www.modelshipbuilder.com



**MORTAR PIT PLANKING - PARTS TEMPLATE**

- 1. Mortar Pit Primary Planking
- 2. Mortar Pit Secondary Planking

1

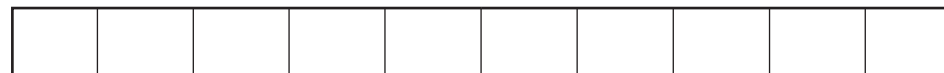
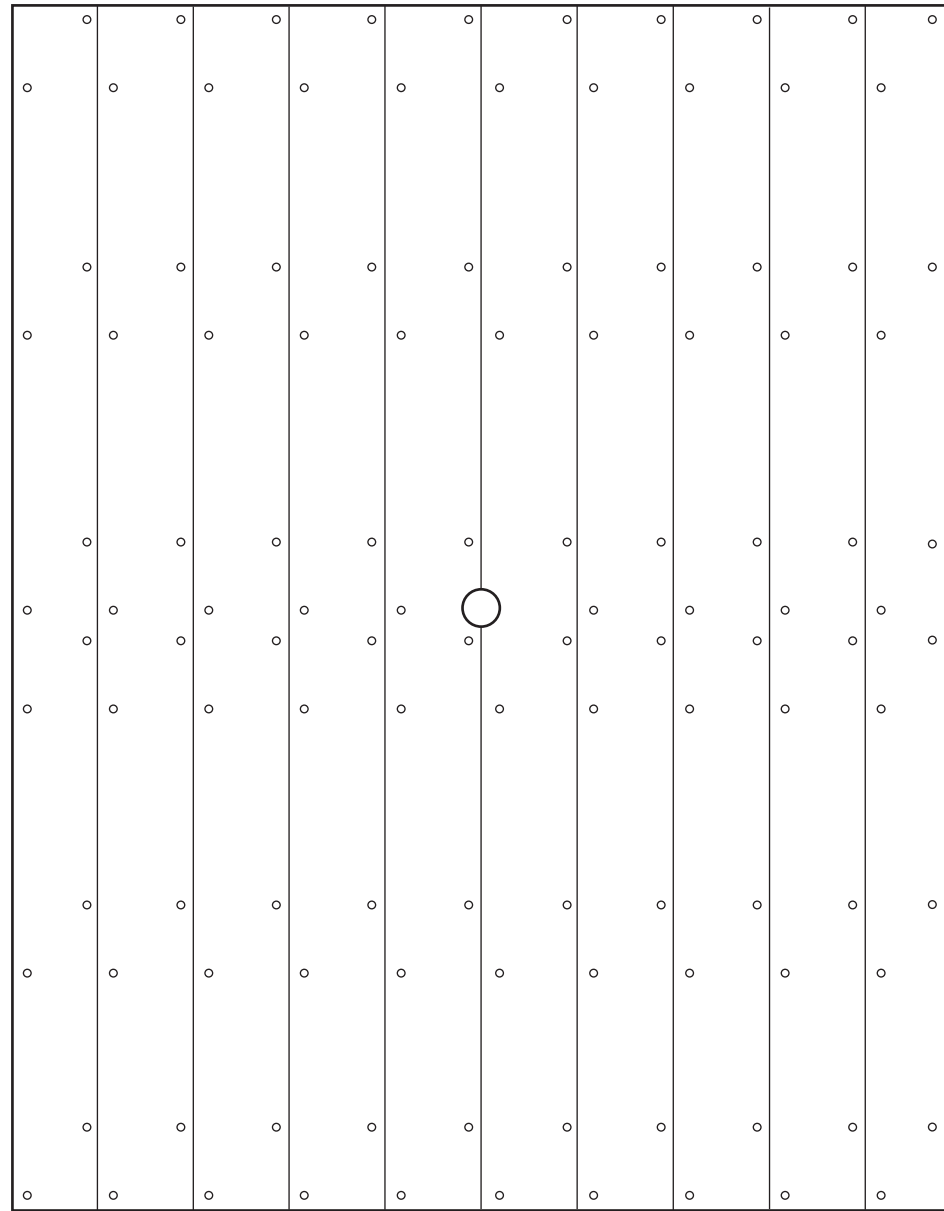

2

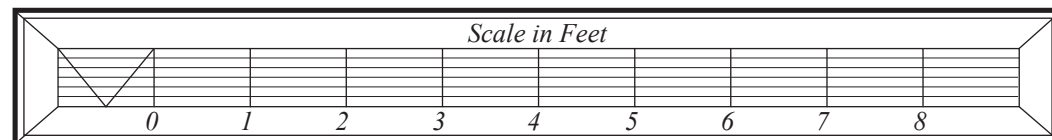
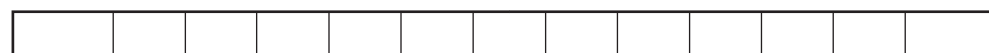
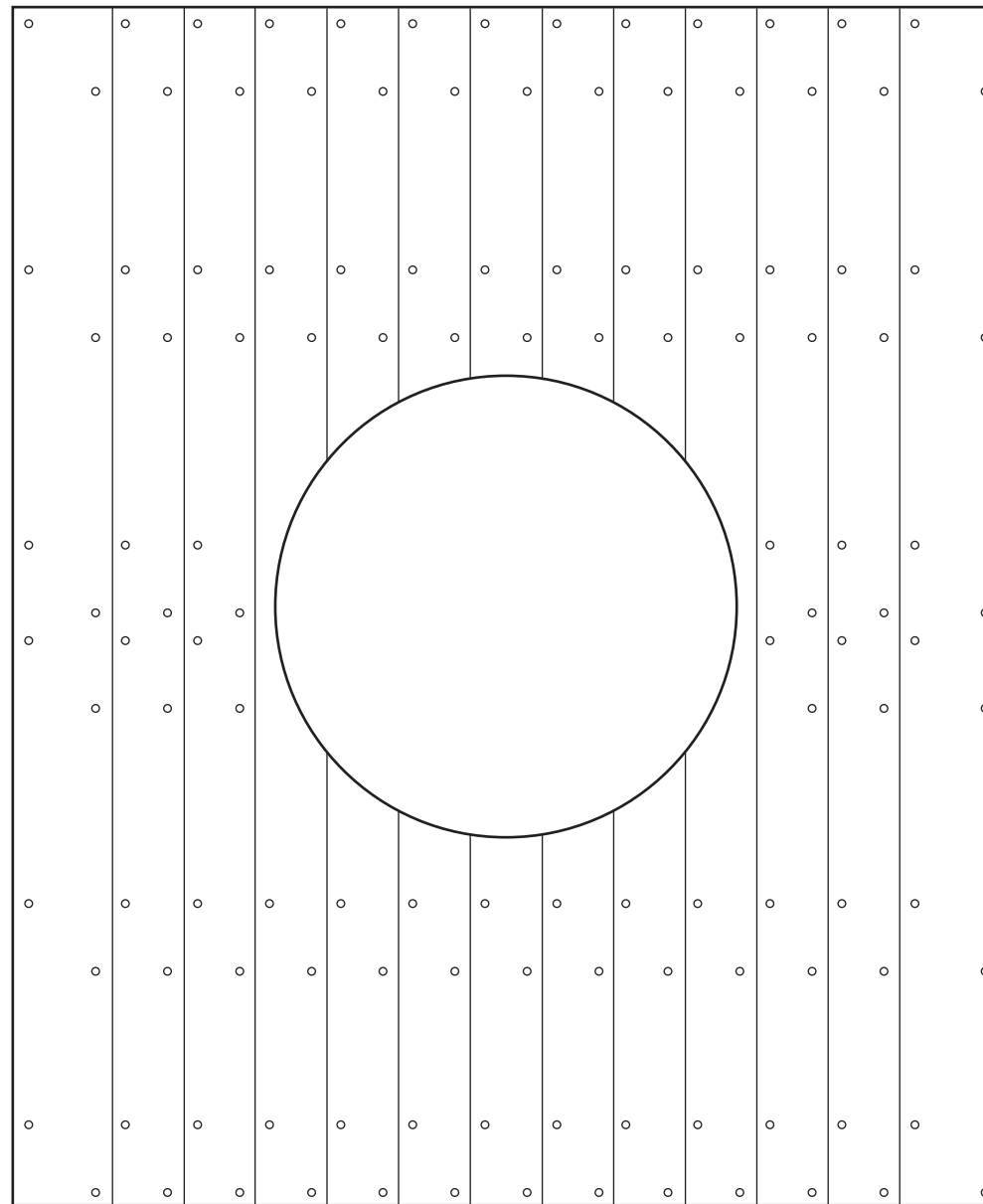



www.modelshipbuilder.com

· BOMB VESSEL ·  
1742

**UPPER DECK CLAMPS**

1. Upper Deck Clamp (Upper Strake)
2. Upper Deck Clamp (Lower Strake)

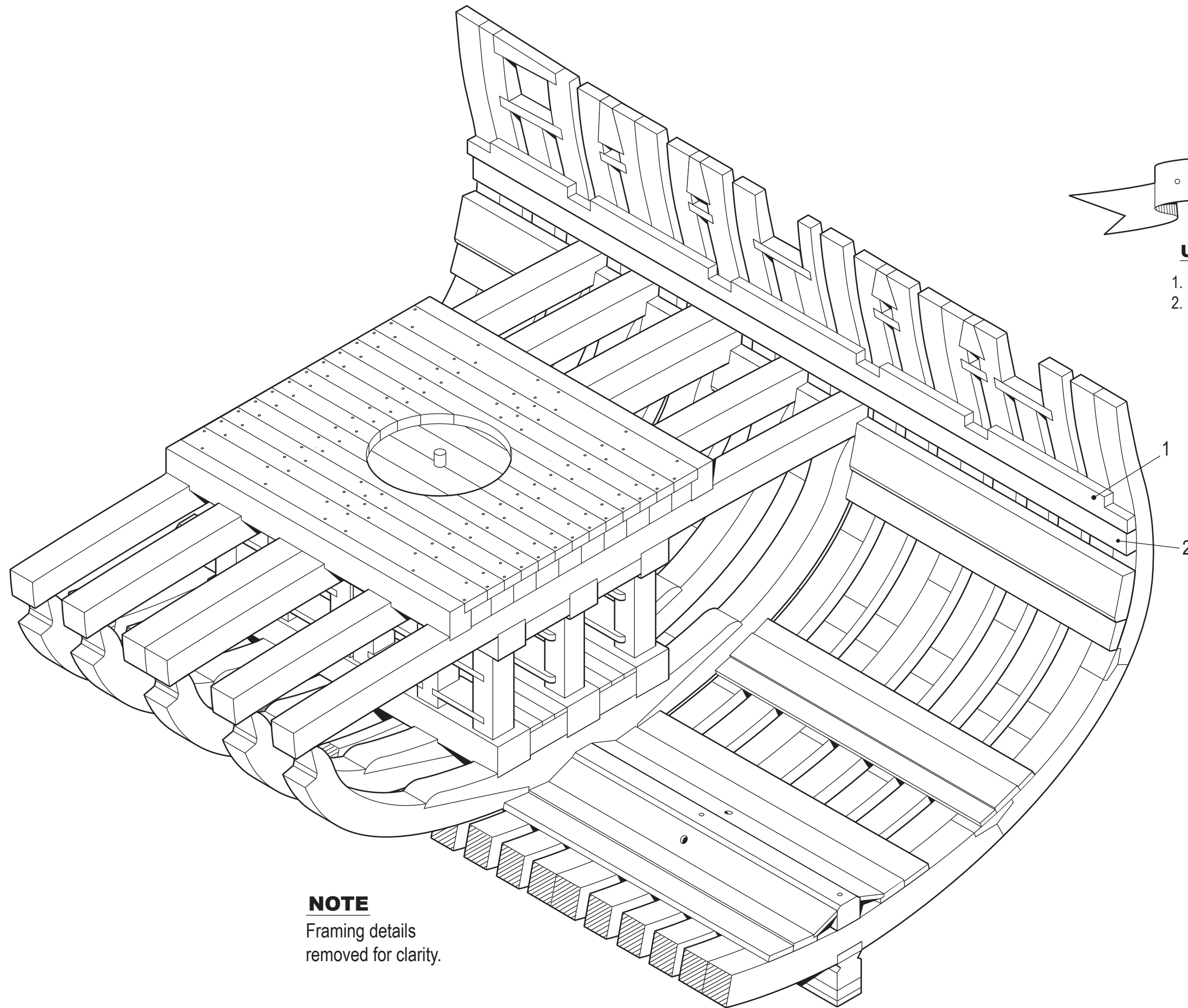

**NOTE**  
Framing details  
removed for clarity.



www.modelshipbuilder.com

# BOMB VESSEL 1742

## MORTAR PIT SUPPORT STANDARDS & CENTERLINE STANCHIONS

- 1. Mortar Pit Support Standard
- 2. Centerline Stanchion

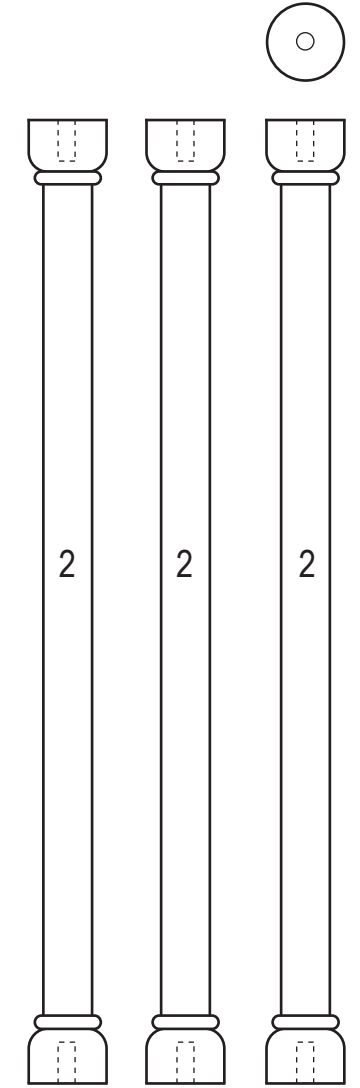
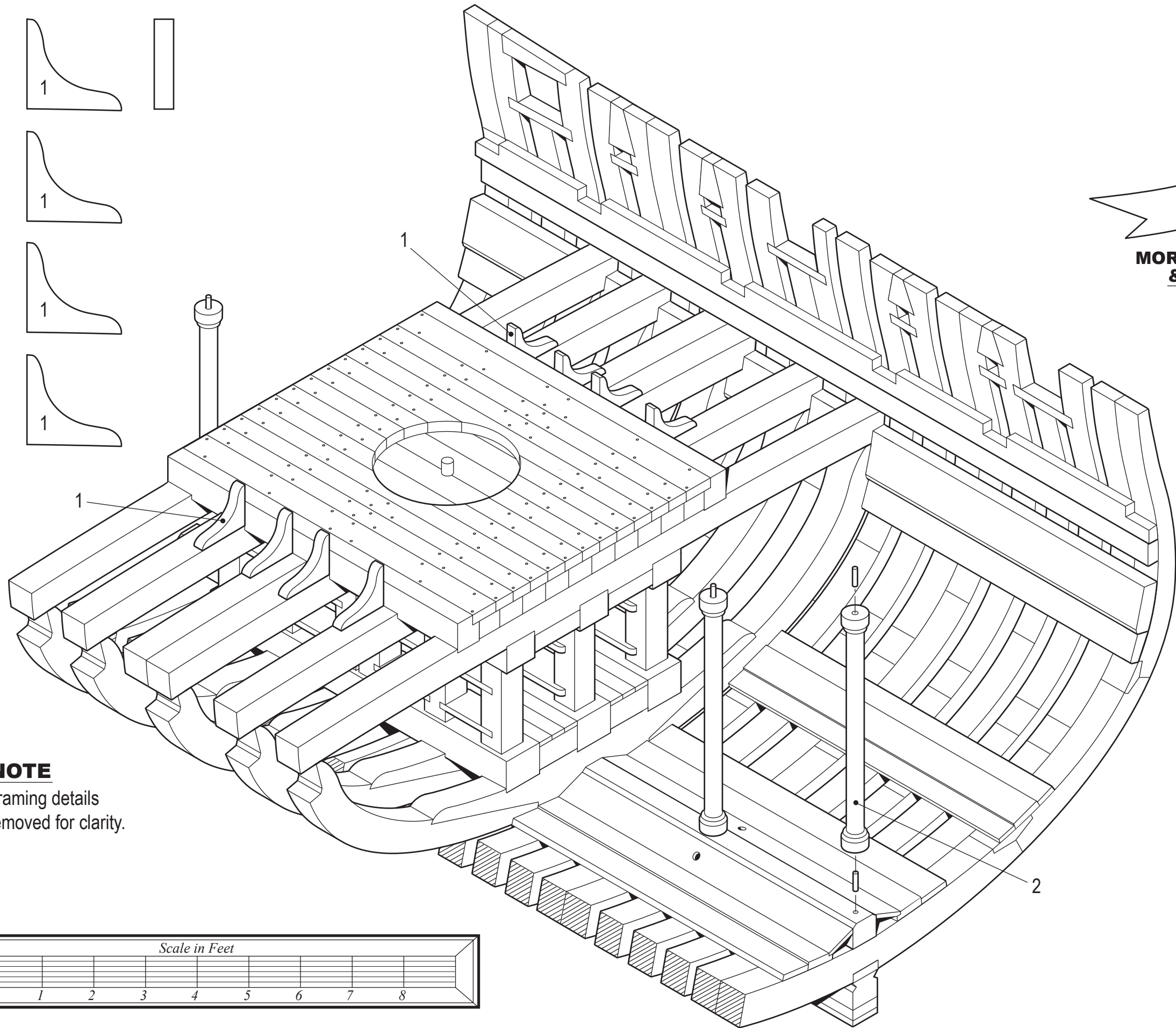
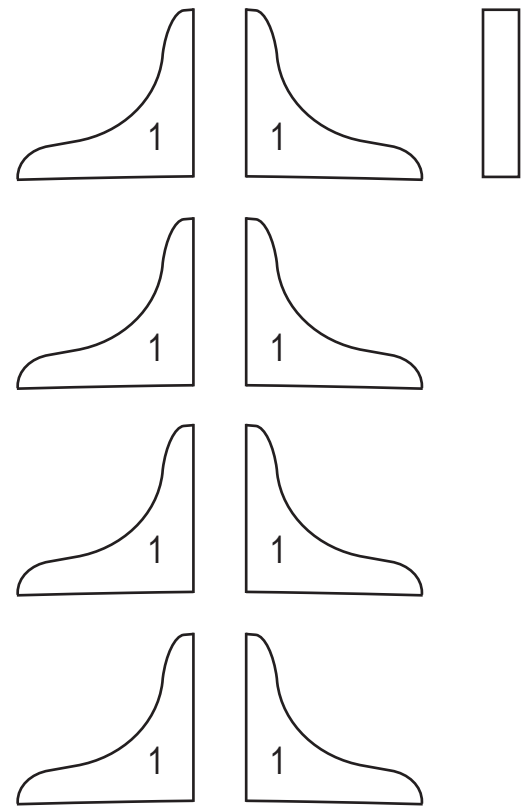

**NOTE**  
Framing details  
removed for clarity.

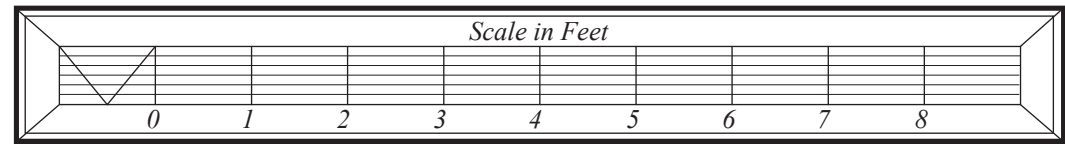



www.modelshipbuilder.com



**UPPER DECK - TOP VIEW STARBOARD SIDE**

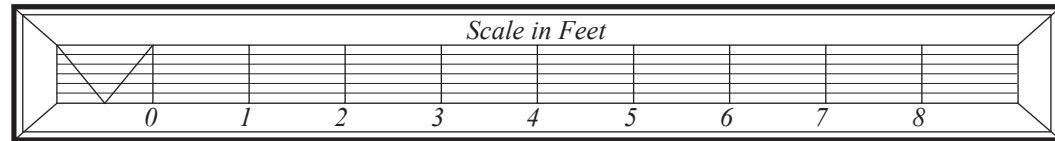

- |                    |                         |                        |
|--------------------|-------------------------|------------------------|
| 1. Upper Deck Beam | 9. Hanging Knee         | 17. Carling            |
| 2. Upper Deck Beam | 10. Hanging Knee        | 18. Carling            |
| 3. Upper Deck Beam | 11. Lodging Knee        | 19. Carling            |
| 4. Half Beam       | 12. Lodging Knee        | 20. Carling            |
| 5. Upper Deck Beam | 13. Lodging Knee        | 21. Main Hatch Carling |
| 6. Upper Deck Beam | 14. Beam Arm            | 22. Ledges             |
| 7. Trimmer Beam    | 15. Double Lodging Knee |                        |
| 8. Angled Carling  | 16. Double Lodging Knee |                        |

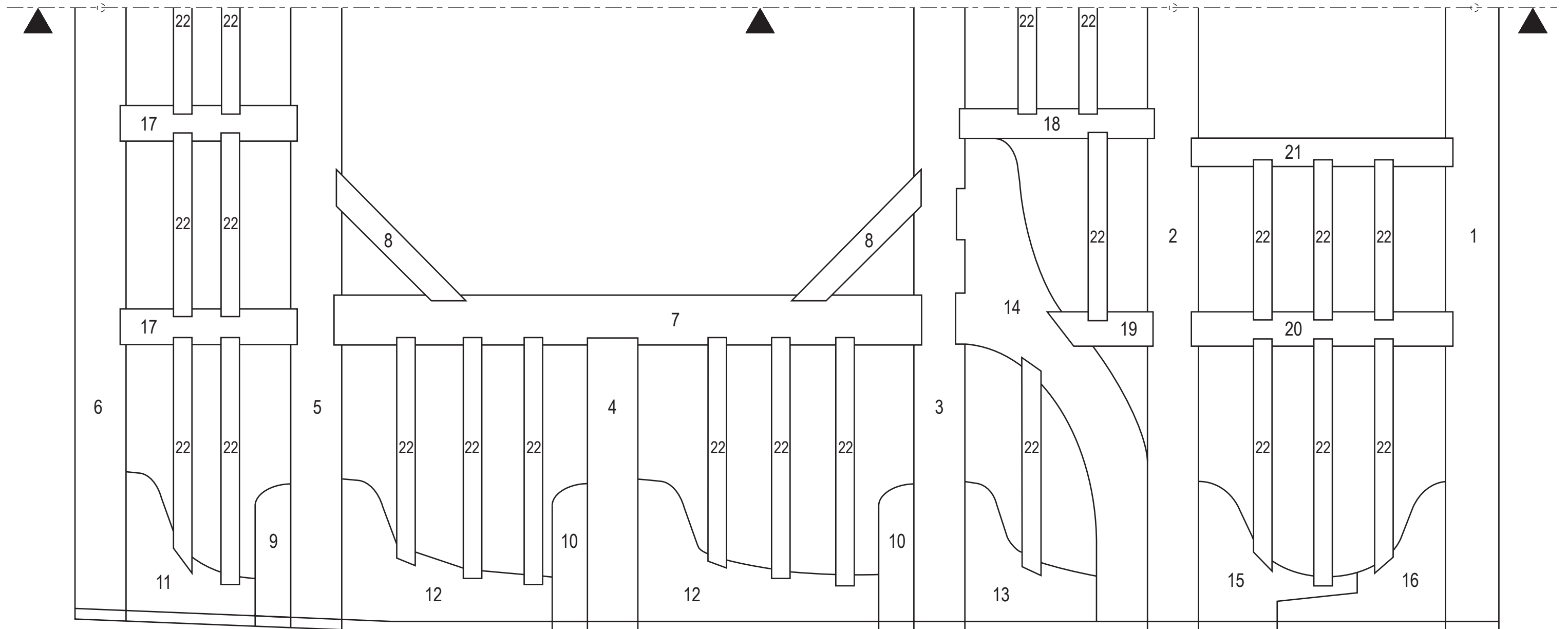



www.modelshipbuilder.com



**UPPER DECK - TOP VIEW PORT SIDE**

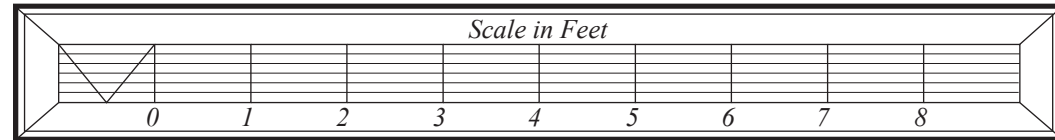

- |                    |                         |                        |
|--------------------|-------------------------|------------------------|
| 1. Upper Deck Beam | 9. Hanging Knee         | 17. Carling            |
| 2. Upper Deck Beam | 10. Hanging Knee        | 18. Carling            |
| 3. Upper Deck Beam | 11. Lodging Knee        | 19. Carling            |
| 4. Half Beam       | 12. Lodging Knee        | 20. Carling            |
| 5. Upper Deck Beam | 13. Lodging Knee        | 21. Main Hatch Carling |
| 6. Upper Deck Beam | 14. Beam Arm            | 22. Ledges             |
| 7. Trimmer Beam    | 15. Double Lodging Knee |                        |
| 8. Angled Carling  | 16. Double Lodging Knee |                        |

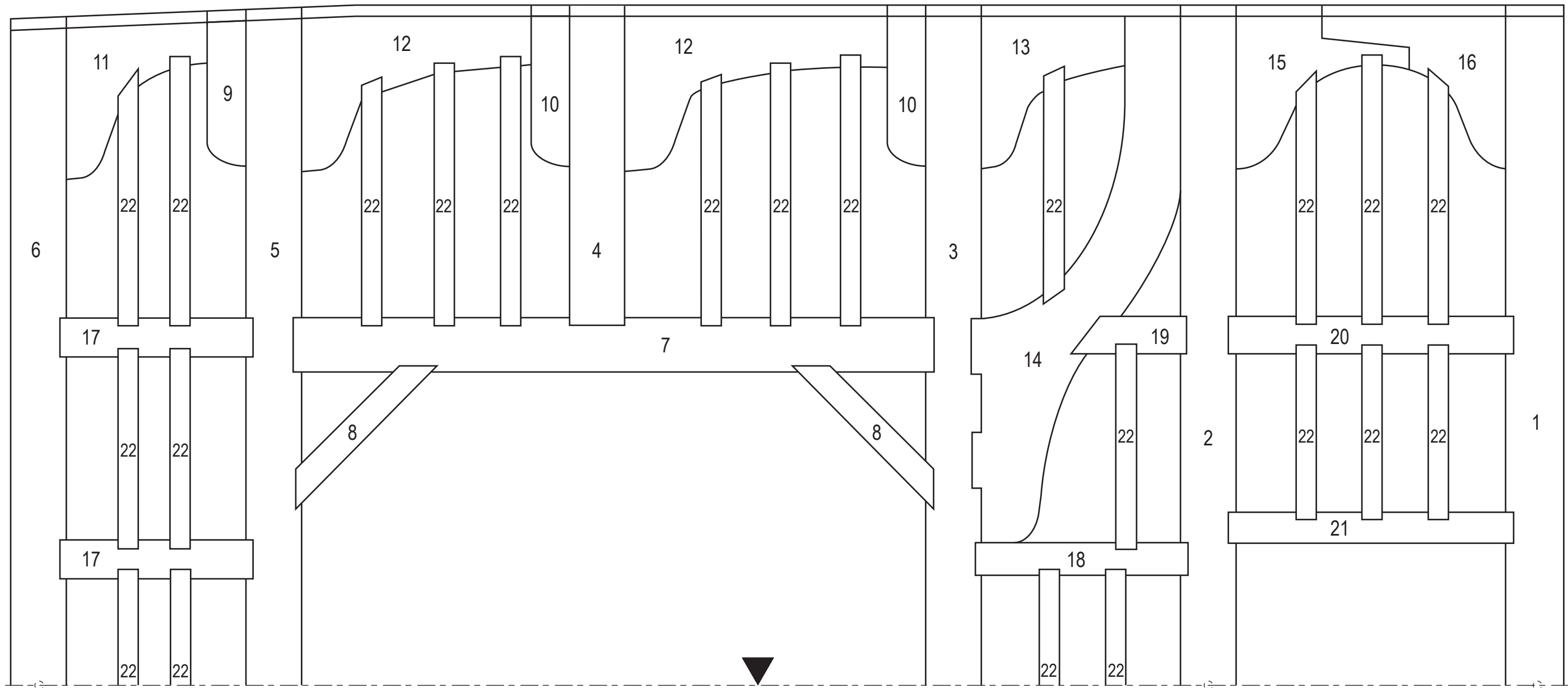

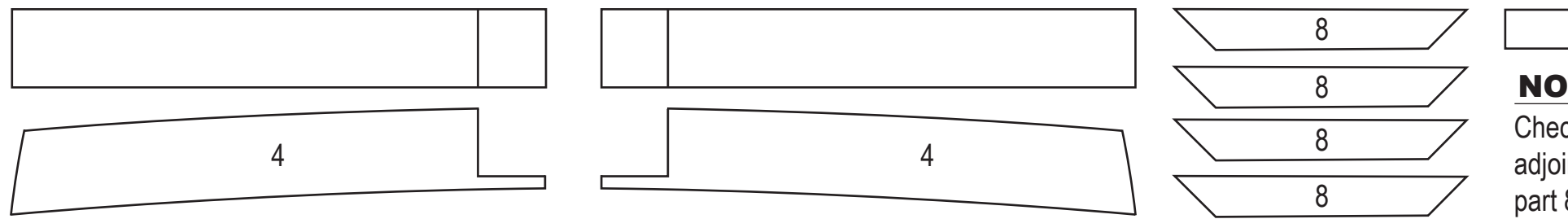

**NOTE**  
Check measurements to adjoining parts before cutting part 8 to final length.



**UPPER DECK TEMPLATES**

- 1. Upper Deck Beam
- 2. Upper Deck Beam
- 3. Upper Deck Beam
- 4. Half Beam
- 5. Upper Deck Beam
- 6. Upper Deck Beam
- 7. Trimmer Beam
- 8. Angled Carling



[www.modelshipbuilder.com](http://www.modelshipbuilder.com)

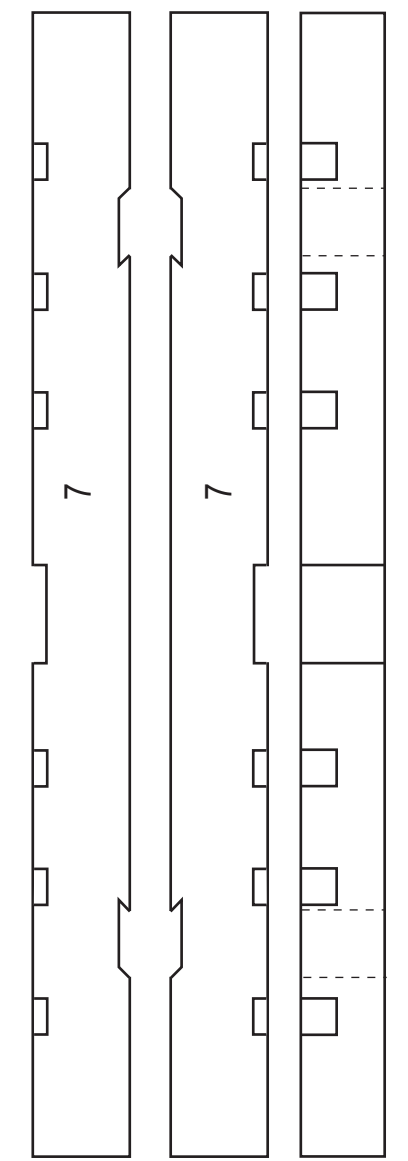
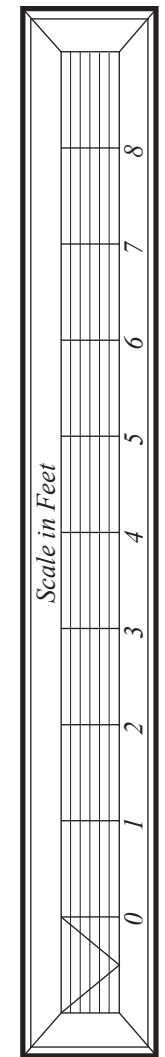
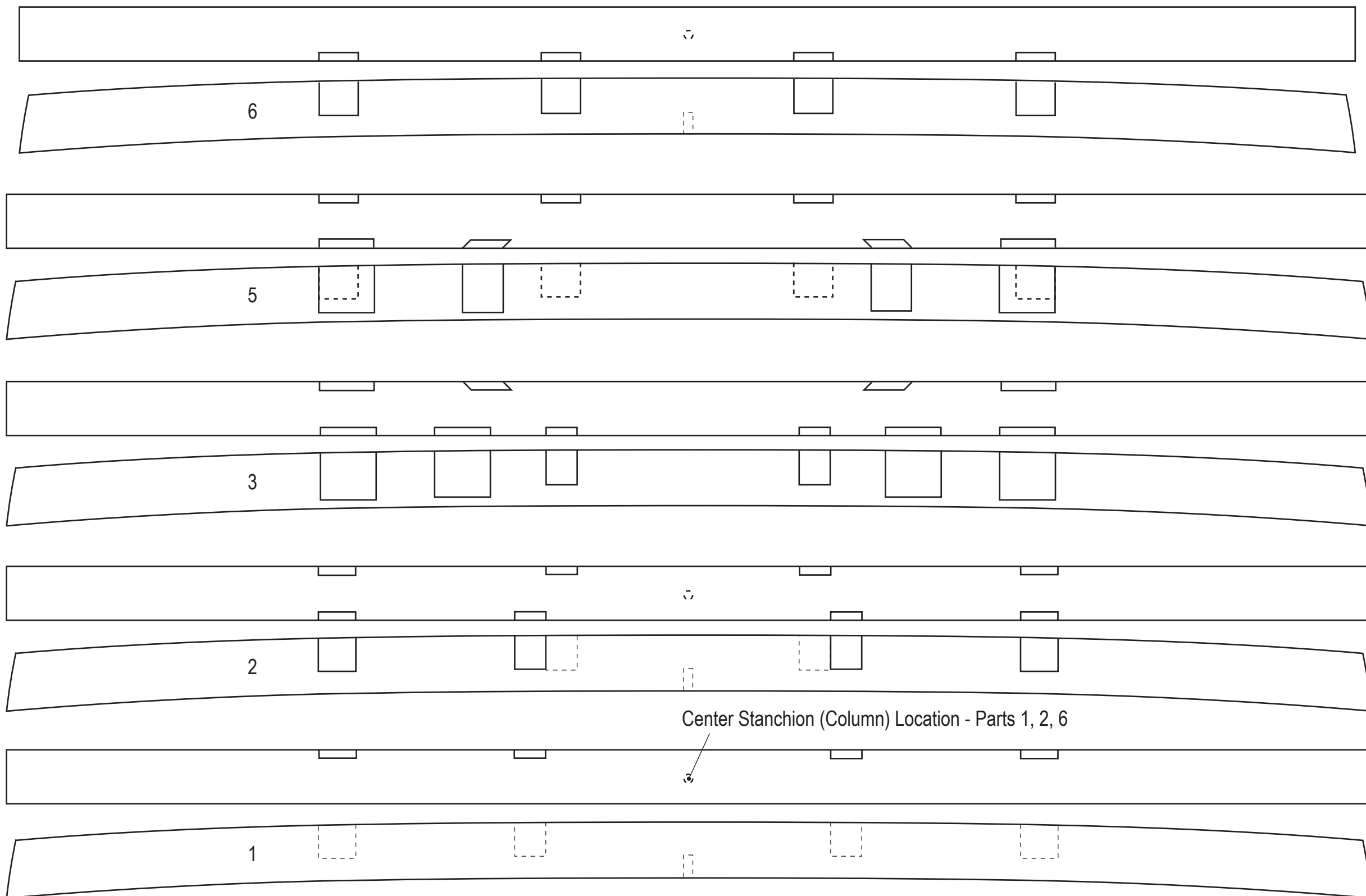



www.modelshipbuilder.com



**UPPER DECK TEMPLATES (Cont.)**

- 9. Hanging Knee
- 10. Hanging Knee
- 11. Lodging Knee
- 12. Lodging Knee
- 13. Lodging Knee
- 14. Beam Arm
- 15. Double Lodging Knee
- 16. Double Lodging Knee
- 17. Carling
- 18. Carling
- 19. Carling
- 20. Carling
- 21. Main Hatch Carling
- 22. Ledges

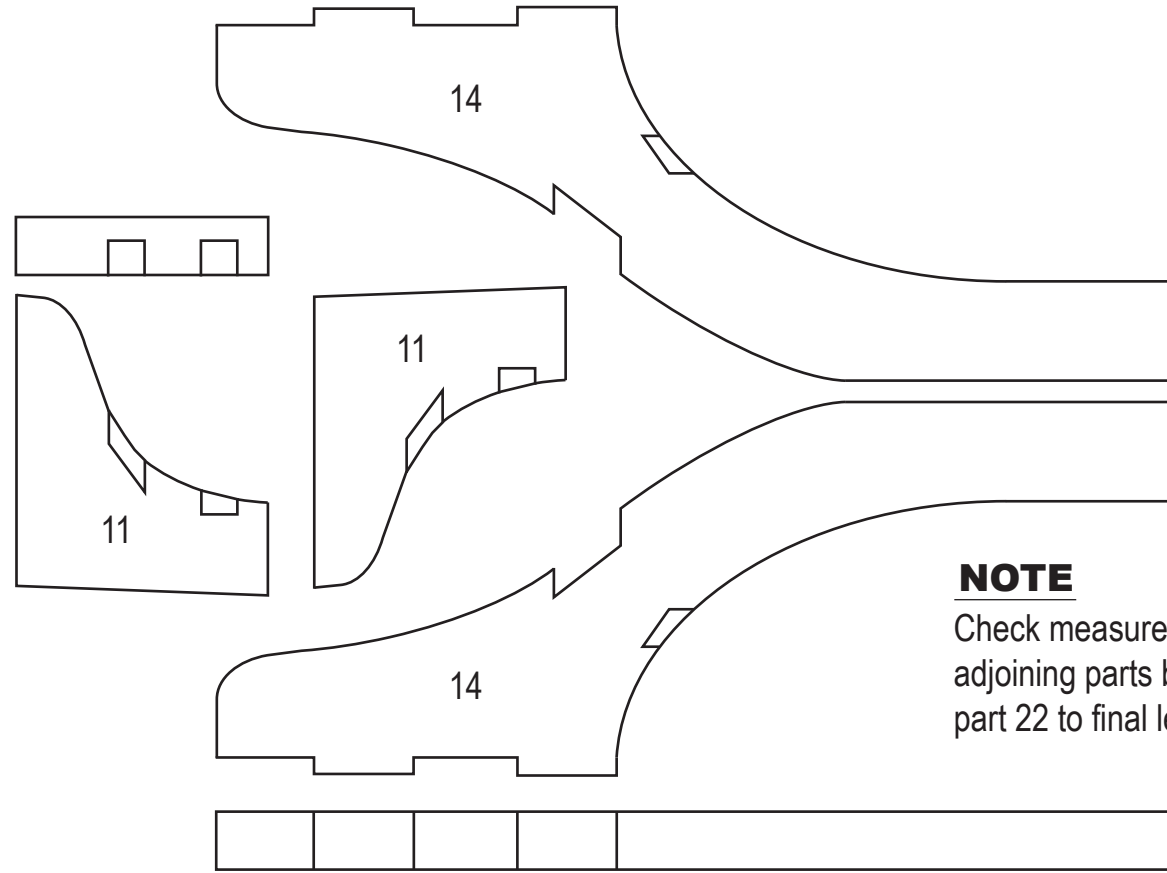
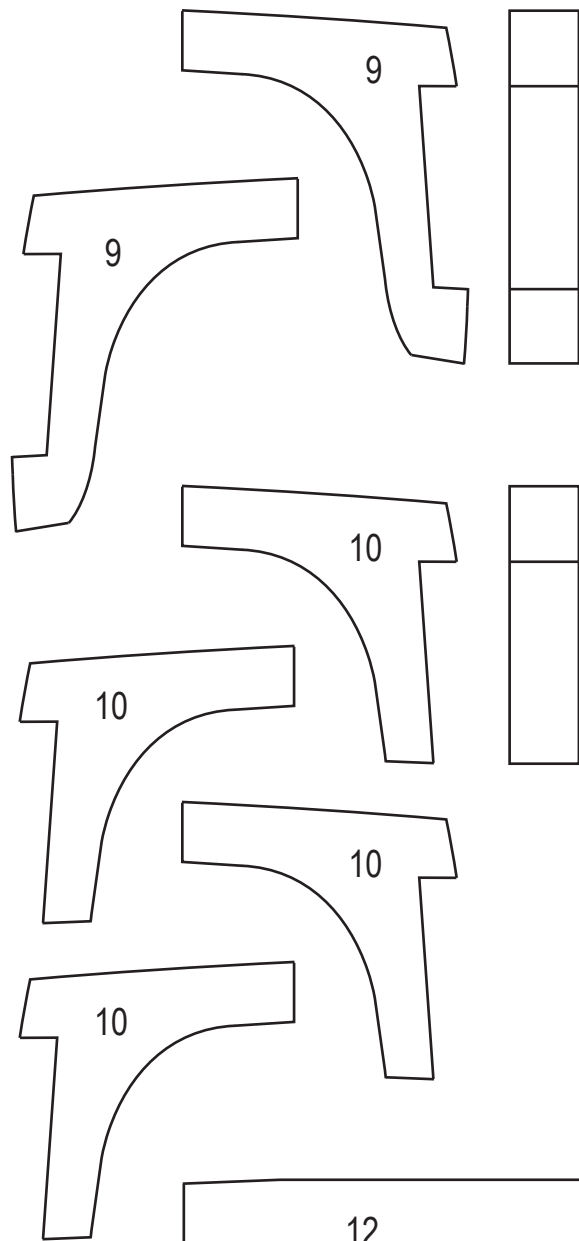

**NOTE**

Check measurements to adjoining parts before cutting part 22 to final lengths.

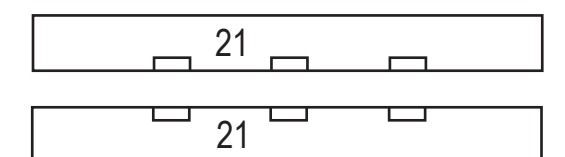
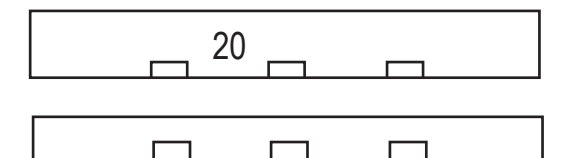
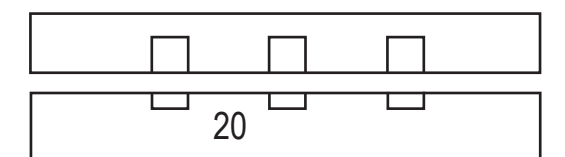
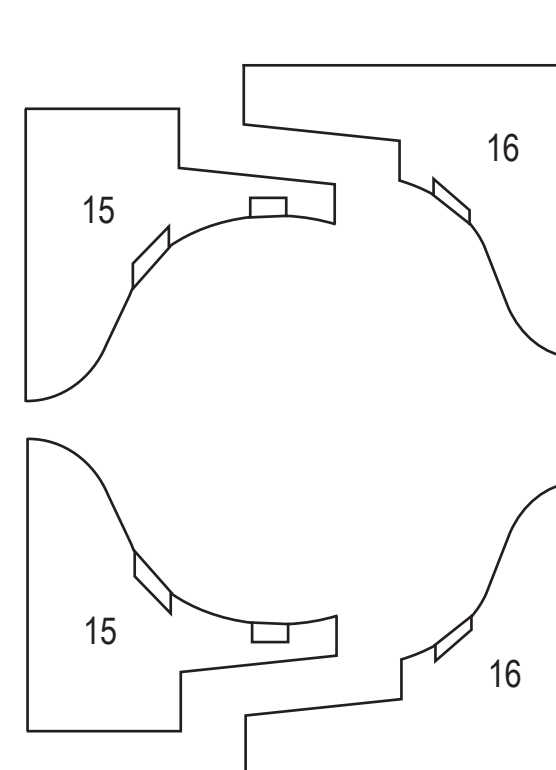
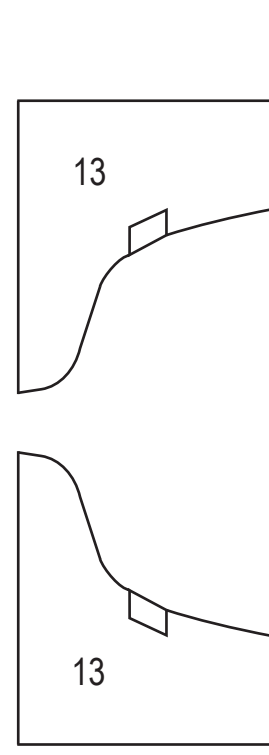
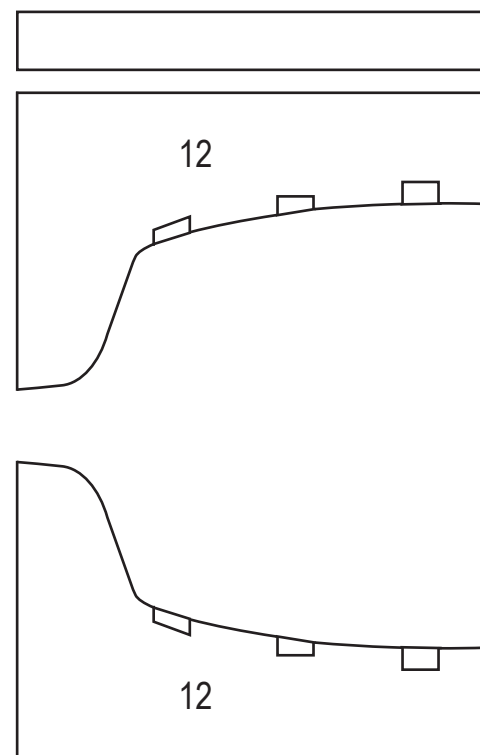
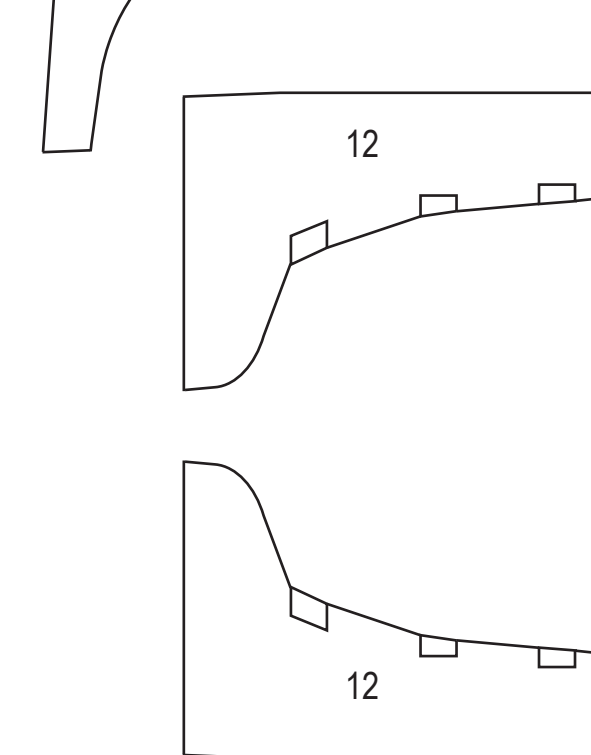
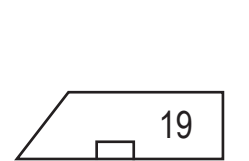
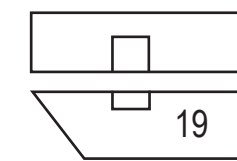
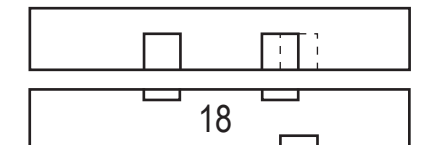
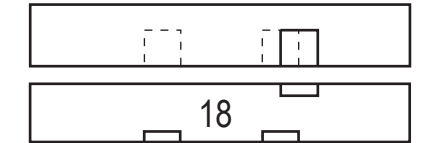
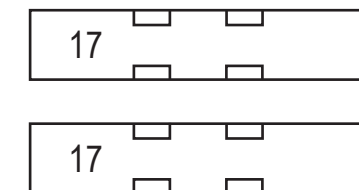
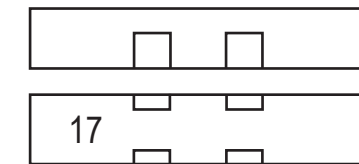
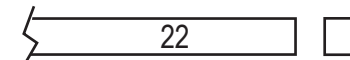
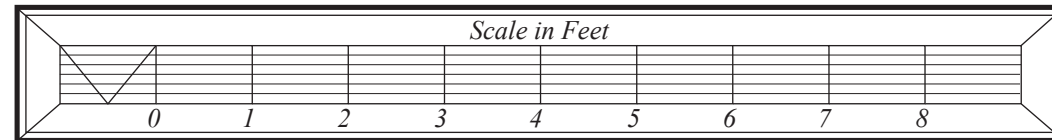



www.modelshipbuilder.com



### UPPER DECK

- 1. Upper Deck Beam
- 2. Upper Deck Beam
- 3. Upper Deck Beam
- 4. Half Beam
- 5. Upper Deck Beam
- 6. Upper Deck Beam
- 7. Trimmer Beam
- 8. Angled Carling

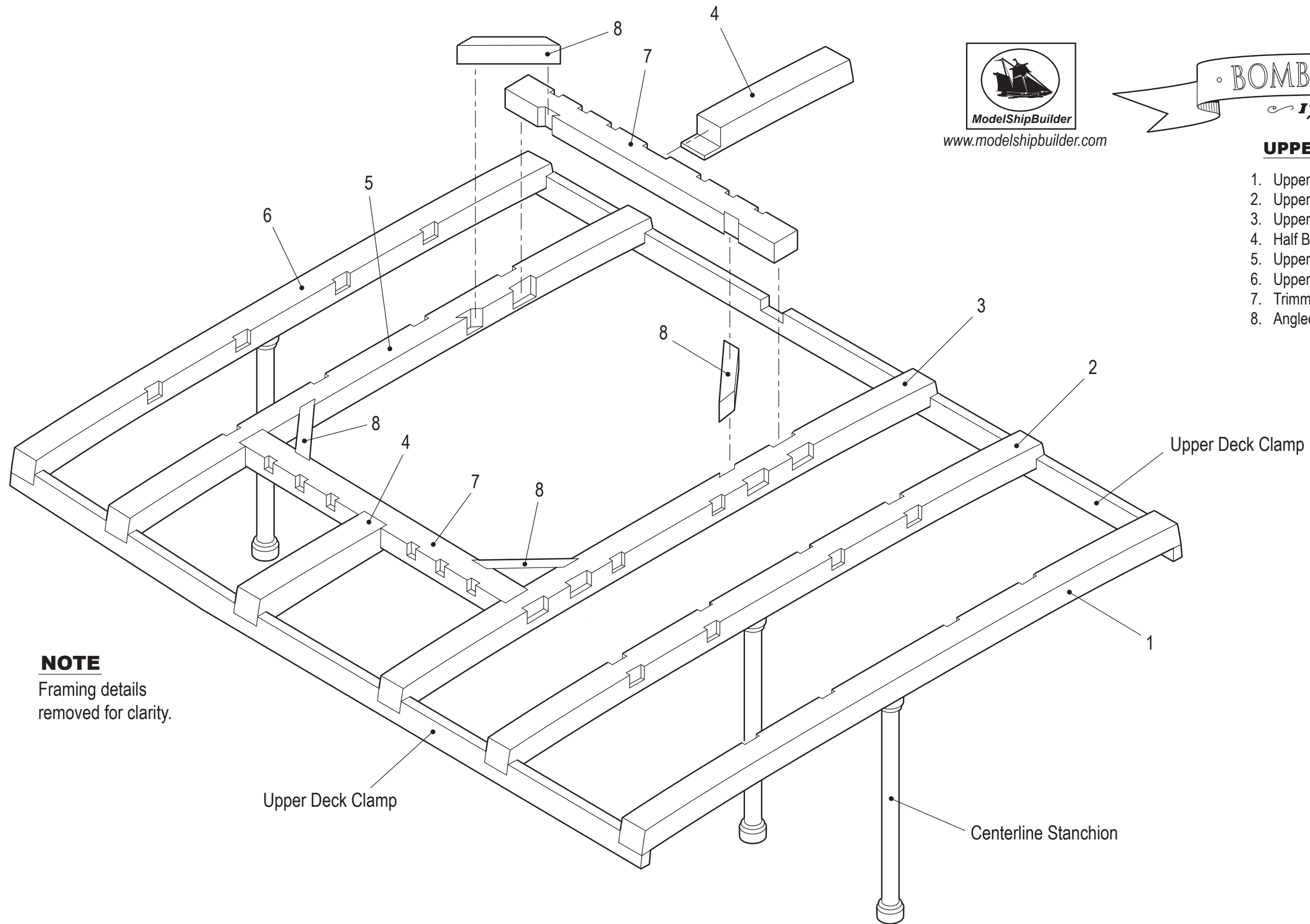

#### NOTE

Framing details removed for clarity.

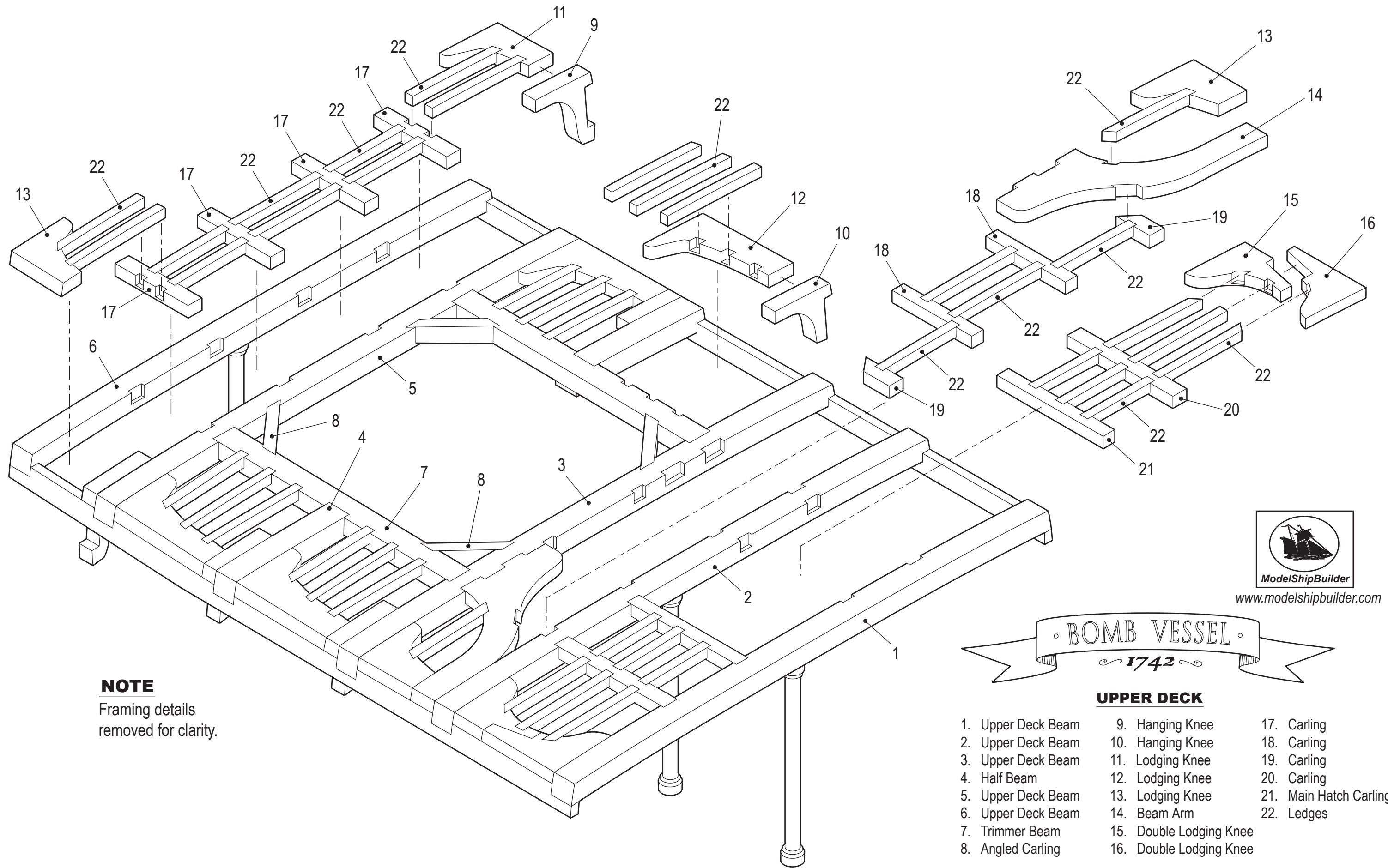

**NOTE**  
Framing details  
removed for clarity.



www.modelshipbuilder.com

• BOMB VESSEL •  
1742

**UPPER DECK**

- |                    |                         |                        |
|--------------------|-------------------------|------------------------|
| 1. Upper Deck Beam | 9. Hanging Knee         | 17. Carling            |
| 2. Upper Deck Beam | 10. Hanging Knee        | 18. Carling            |
| 3. Upper Deck Beam | 11. Lodging Knee        | 19. Carling            |
| 4. Half Beam       | 12. Lodging Knee        | 20. Carling            |
| 5. Upper Deck Beam | 13. Lodging Knee        | 21. Main Hatch Carling |
| 6. Upper Deck Beam | 14. Beam Arm            | 22. Ledges             |
| 7. Trimmer Beam    | 15. Double Lodging Knee |                        |
| 8. Angled Carling  | 16. Double Lodging Knee |                        |



www.modelshipbuilder.com

# BOMB VESSEL 1742

## MORTAR PIT

- 1. Outboard Bulkhead
- 2. Angled Bulkhead
- 3. Transverse Bulkhead
- 4. Ring Bolt

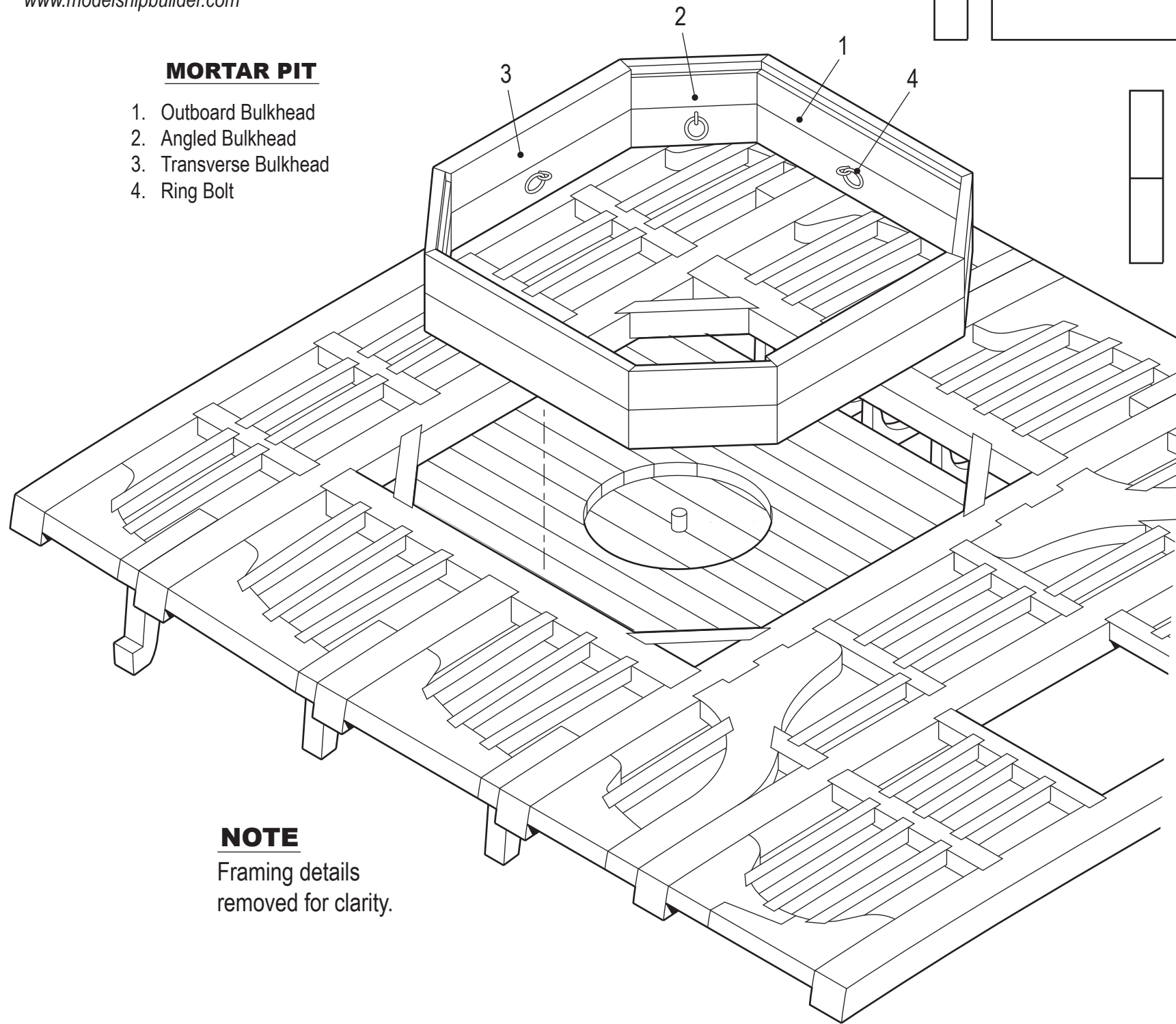

### NOTE

Framing details removed for clarity.

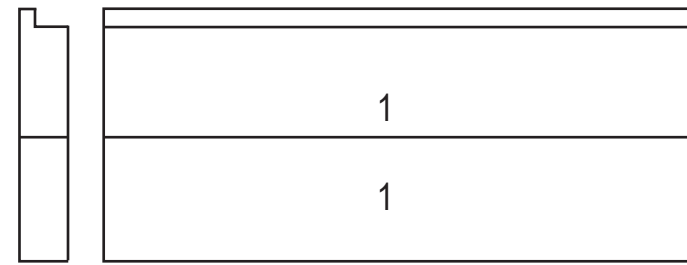

Cut 2 sets - parts 1 and 3.

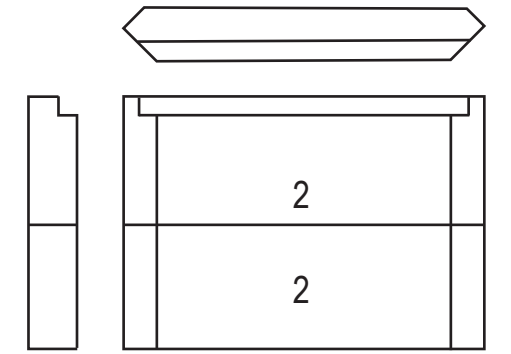
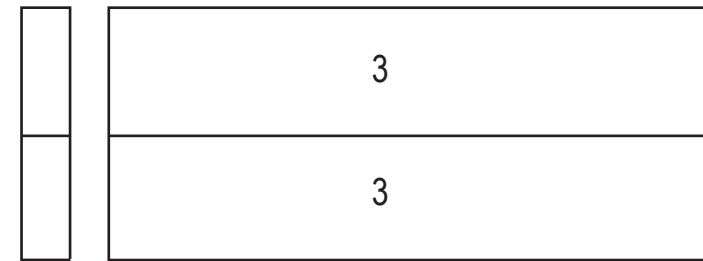

Cut 4 sets - part 2.

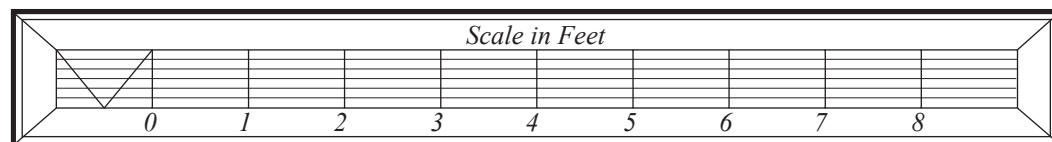
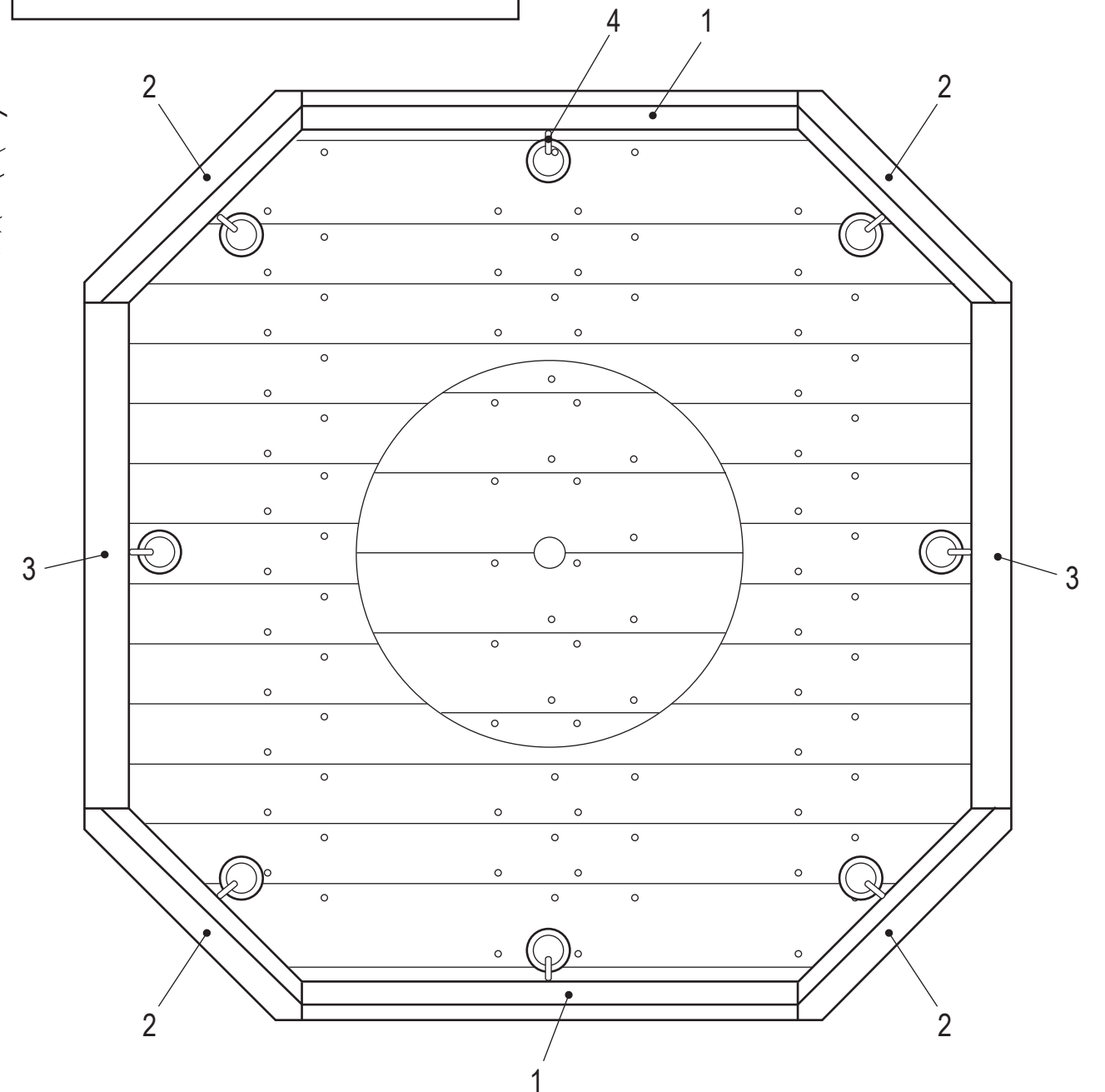



www.modelshipbuilder.com



### MAIN HATCHWAY

- 1. Hatch Cover Boards
- 2. Lifting Rings
- 3. Coaming
- 4. Head Ledge
- 5. Batten

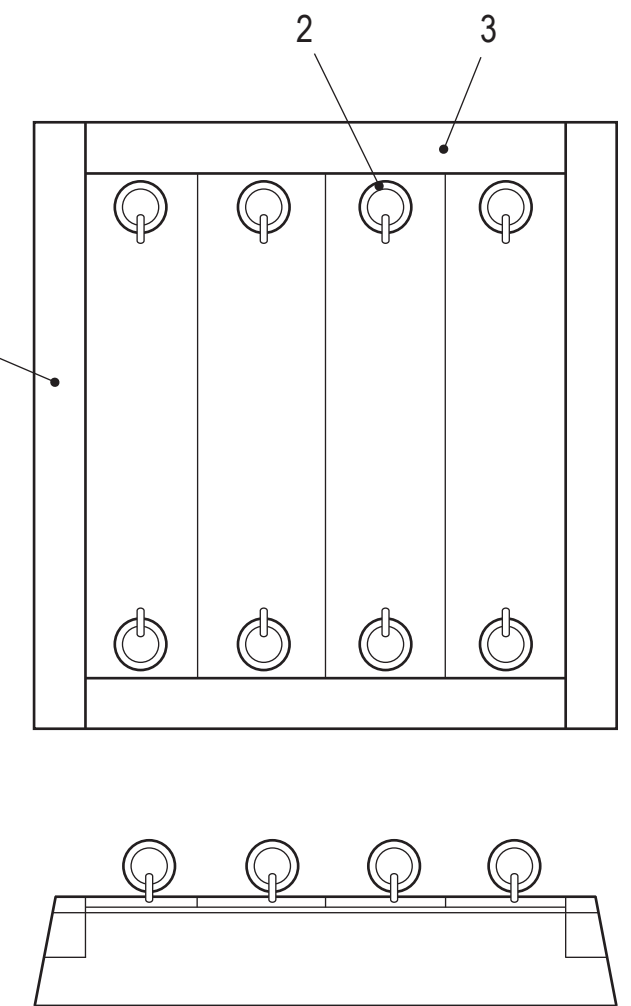
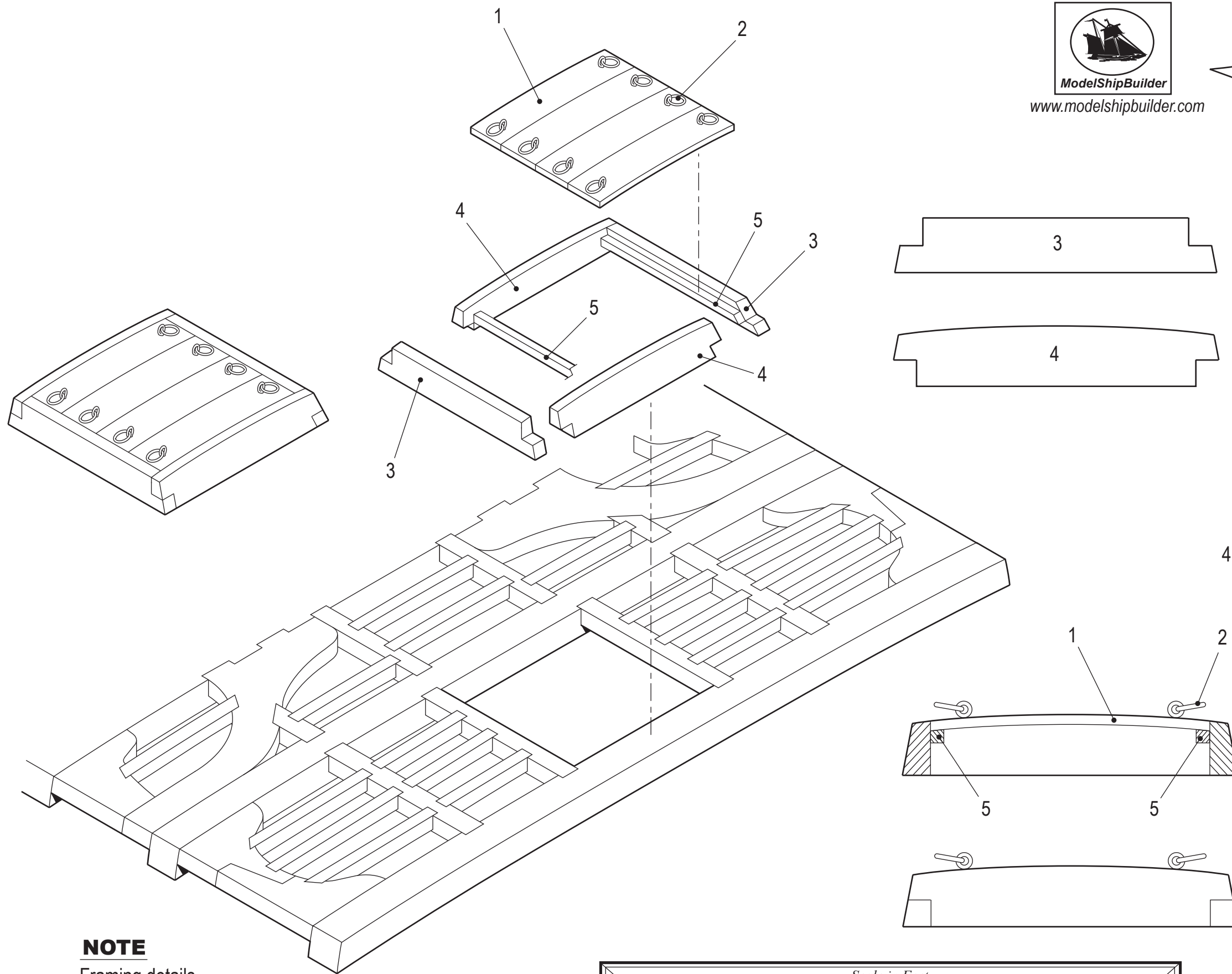

**NOTE**  
Framing details  
removed for clarity.

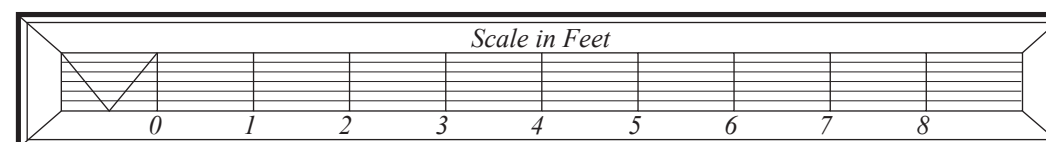

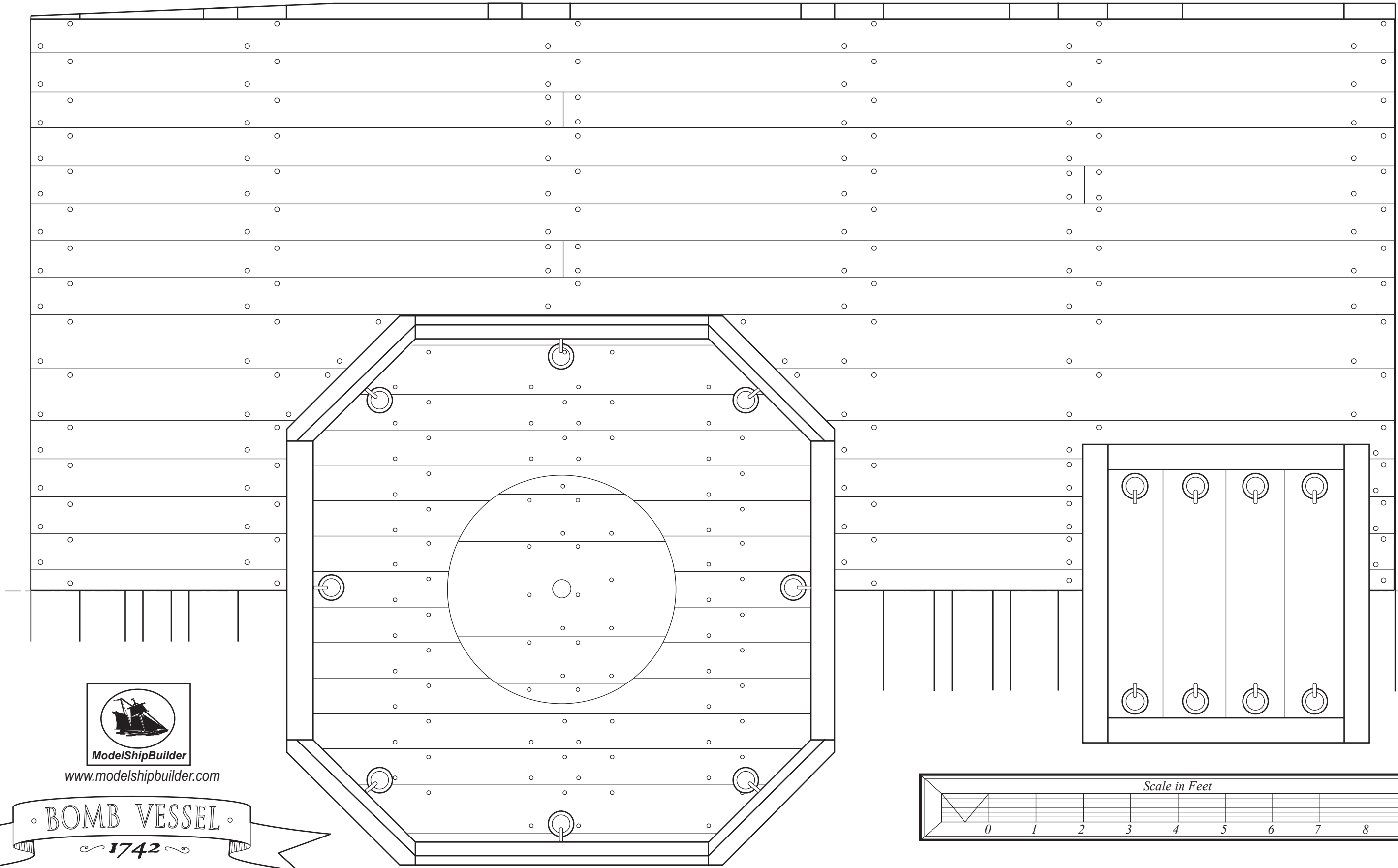

ModelShipBuilder  
www.modelshipbuilder.com

◦ BOMB VESSEL ◦  
1742

**DECK PLANKING - PORT SIDE ONLY**

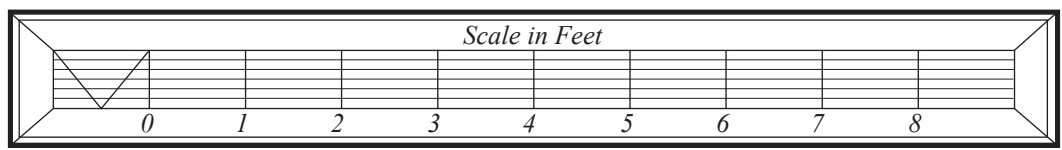

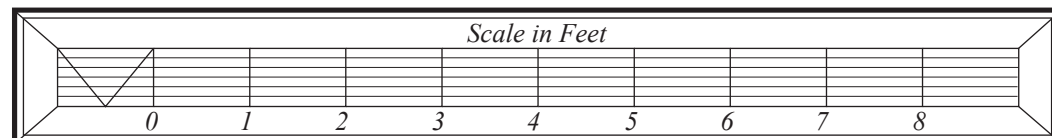
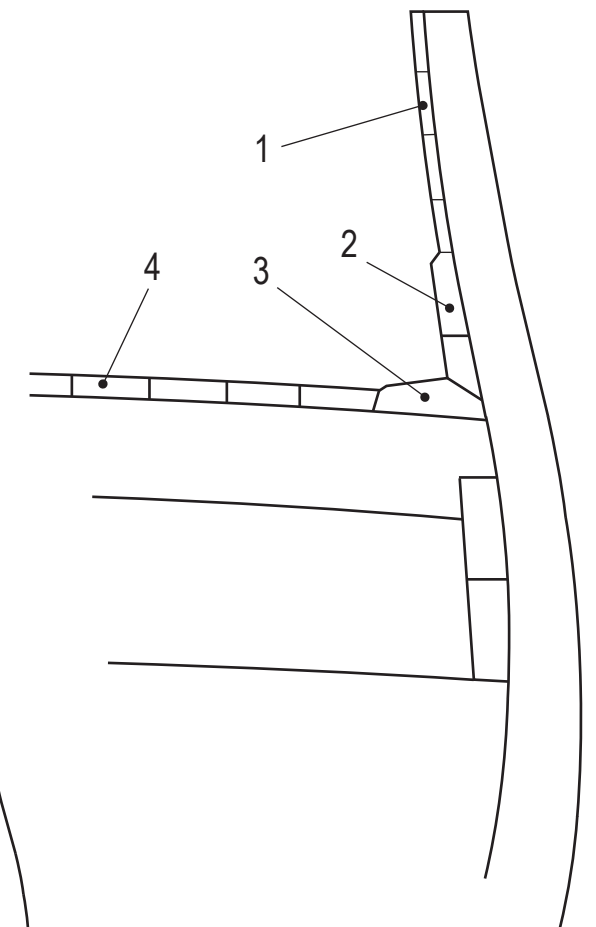
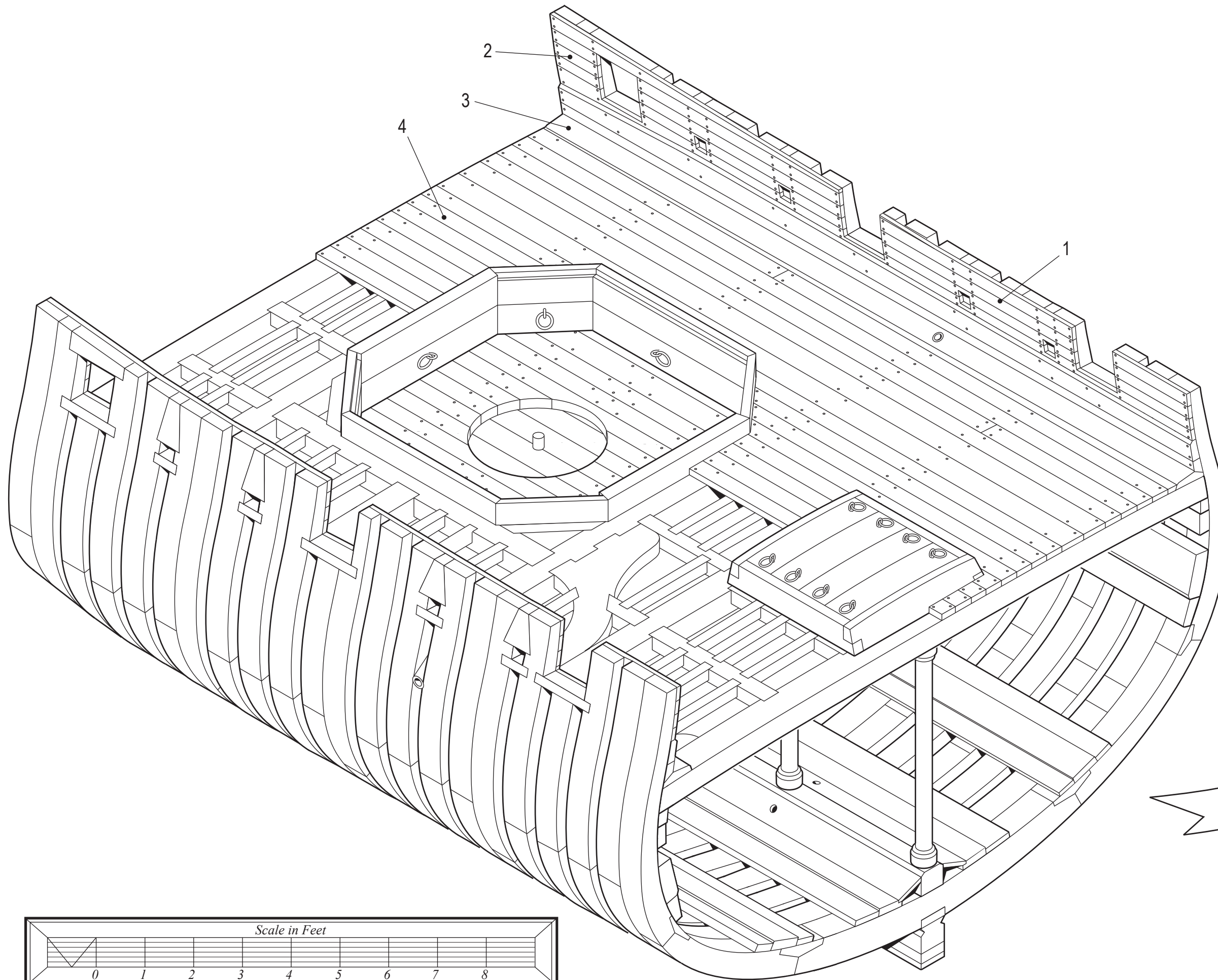

www.modelshipbuilder.com



**INTERNAL HULL PLANKING**

- 1. Lining
- 2. Spirketing
- 3. Waterway
- 4. Deck Planking

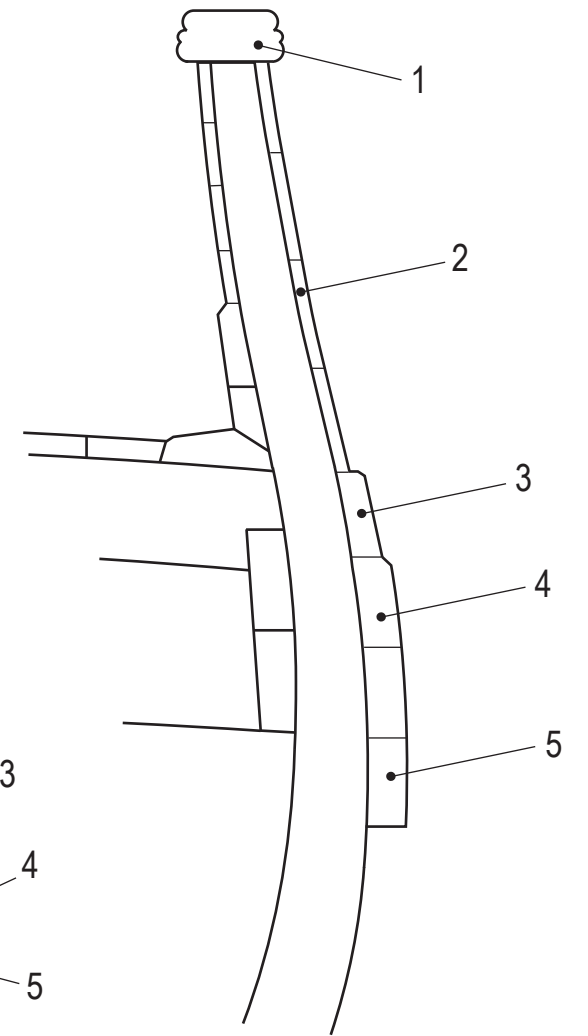
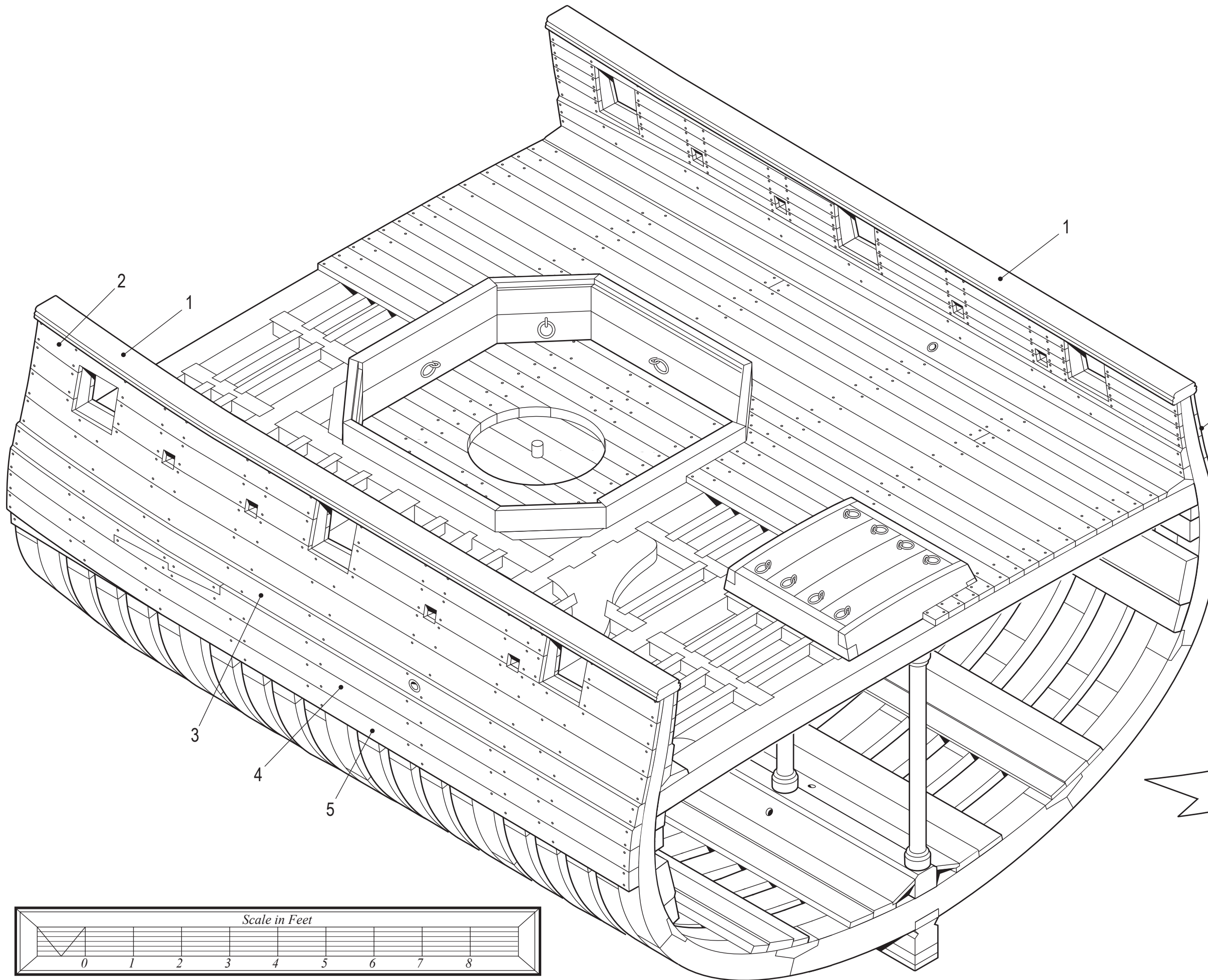

www.modelshipbuilder.com

**BOMB VESSEL**  
1742

**EXTERNAL HULL PLANKING**

- 1. Sheer Rail
- 2. Side Planking
- 3. Upper Main Wale
- 4. Filling Wale
- 5. Lower Main Wale

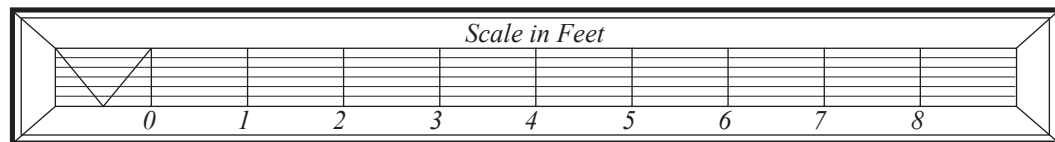



www.modelshipbuilder.com



### 13 IN MORTAR & BED

- 1. Side Cheek
- 2. Transverse Transom
- 3. Fore Transverse Timber Baulks
- 4. Transverse Timber Baulks
- 5. Timber Baulk
- 6. Upper Transverse Timber Baulks
- 7. Filling Timber
- 8. Turntable Base
- 9. Support
- 10. Cap Square and Hinge
- 11. Cap Square Keep
- 12. Retaining Gib
- 13. Ring Bolt (for Lifting)
- 14. Ring Bolt
- 15. Muzzle Bore

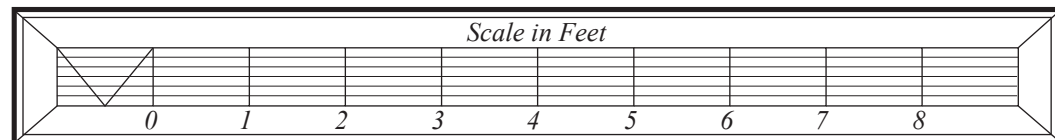
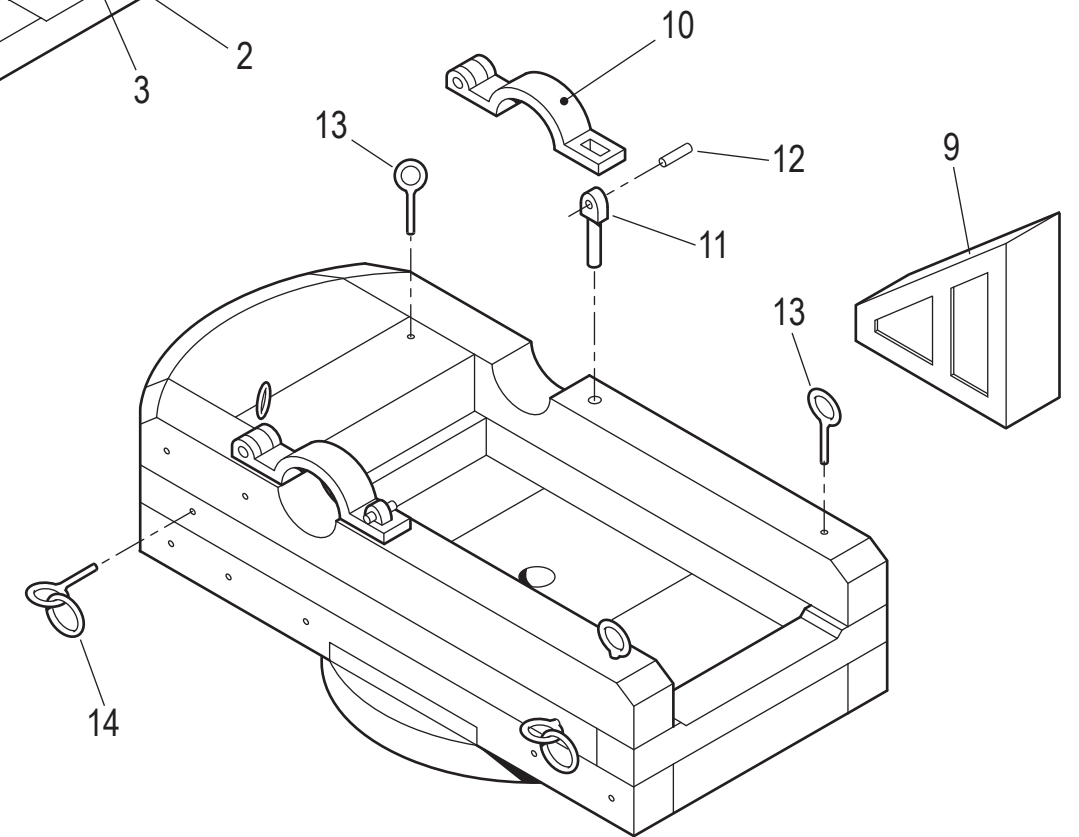
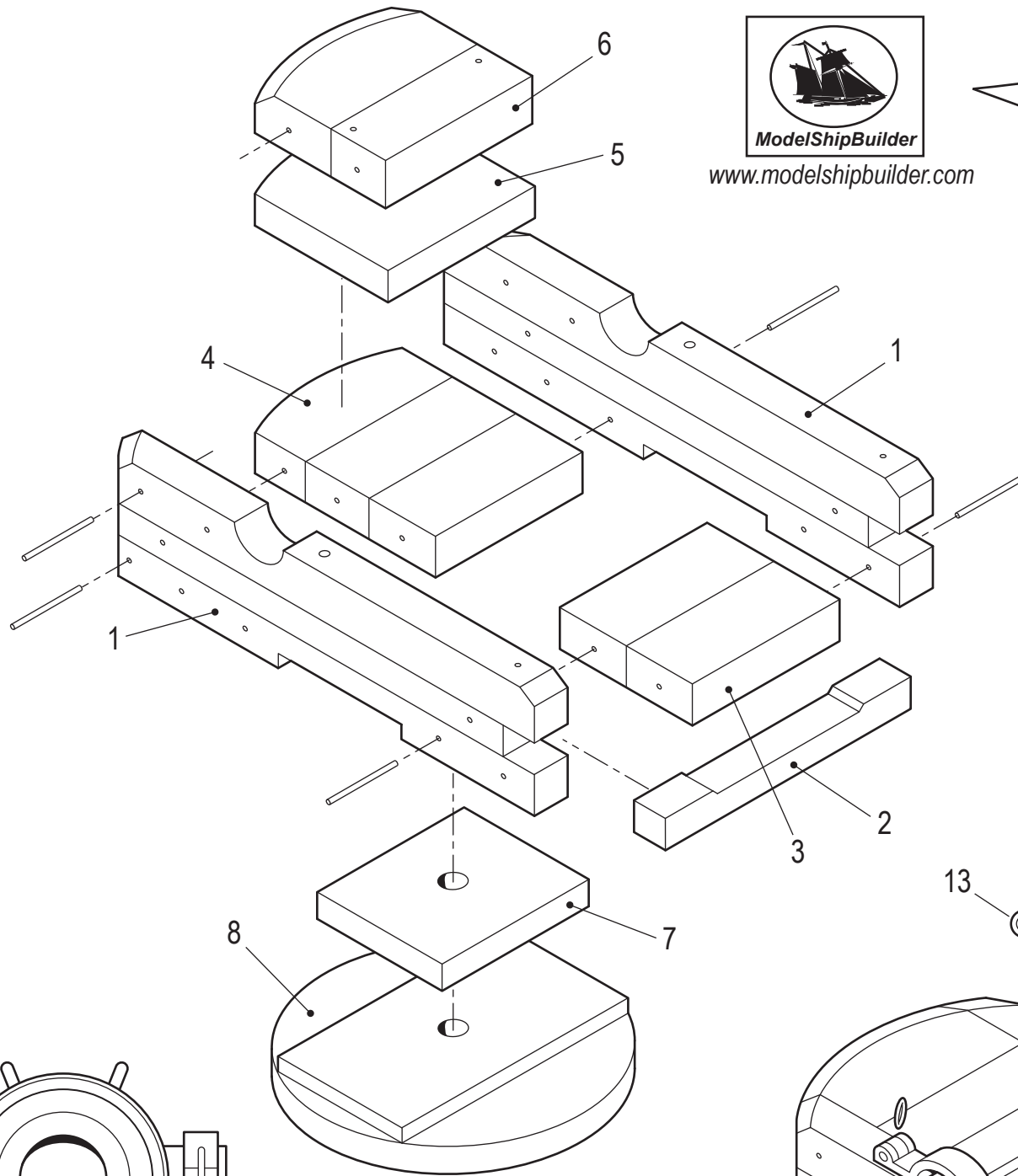
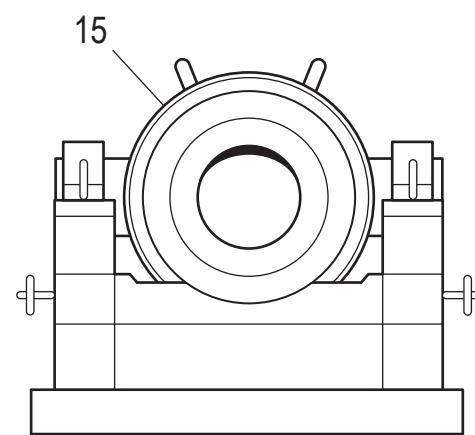
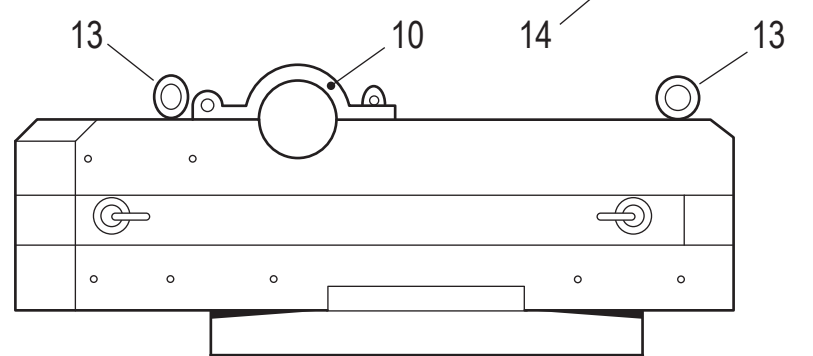
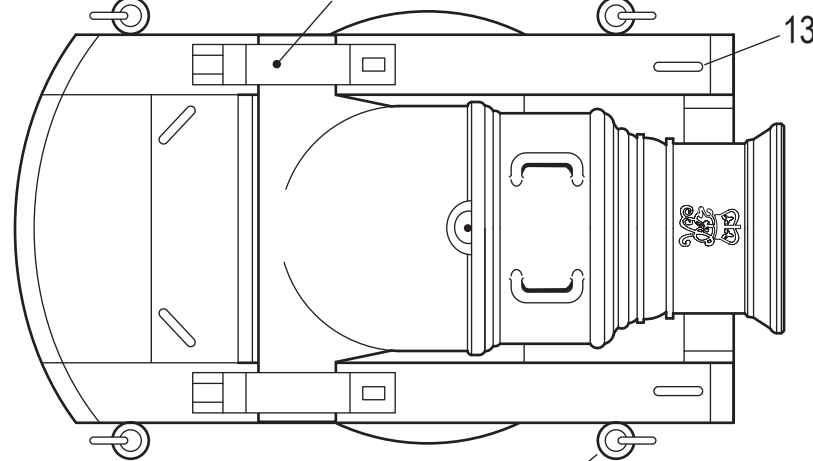
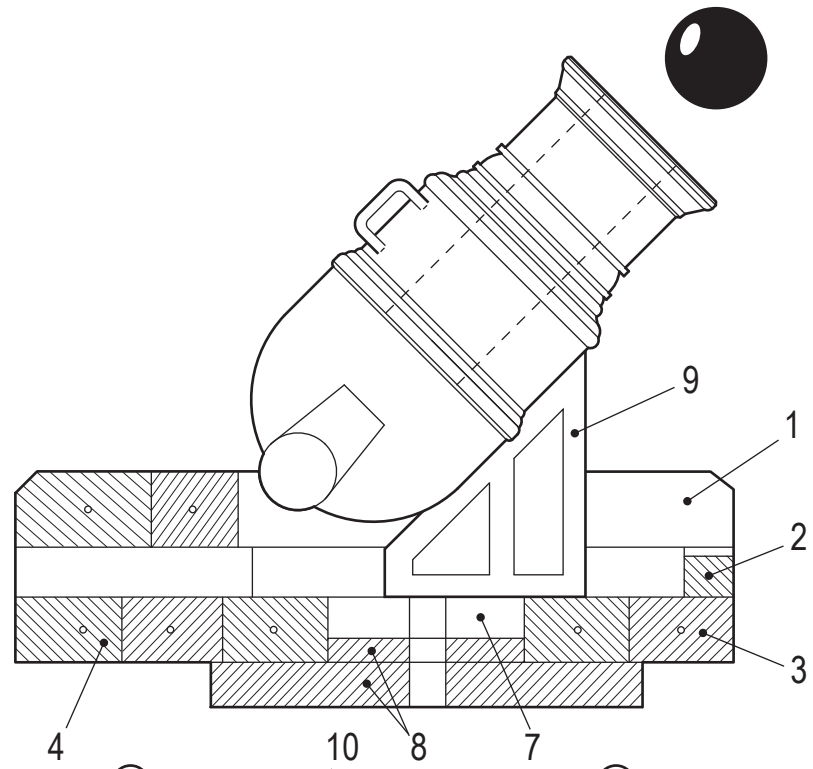

◦ BOMB VESSEL ◦  
1742

**13 IN MORTAR & BED - PARTS TEMPLATE**

1. Side Cheek
2. Transverse Transom
3. Fore Transverse Timber Baulks
4. Transverse Timber Baulks
5. Timber Baulk
6. Upper Transverse Timber Baulks
7. Filling Timber
8. Turntable Base
9. Support



ModelShipBuilder  
www.modelshipbuilder.com

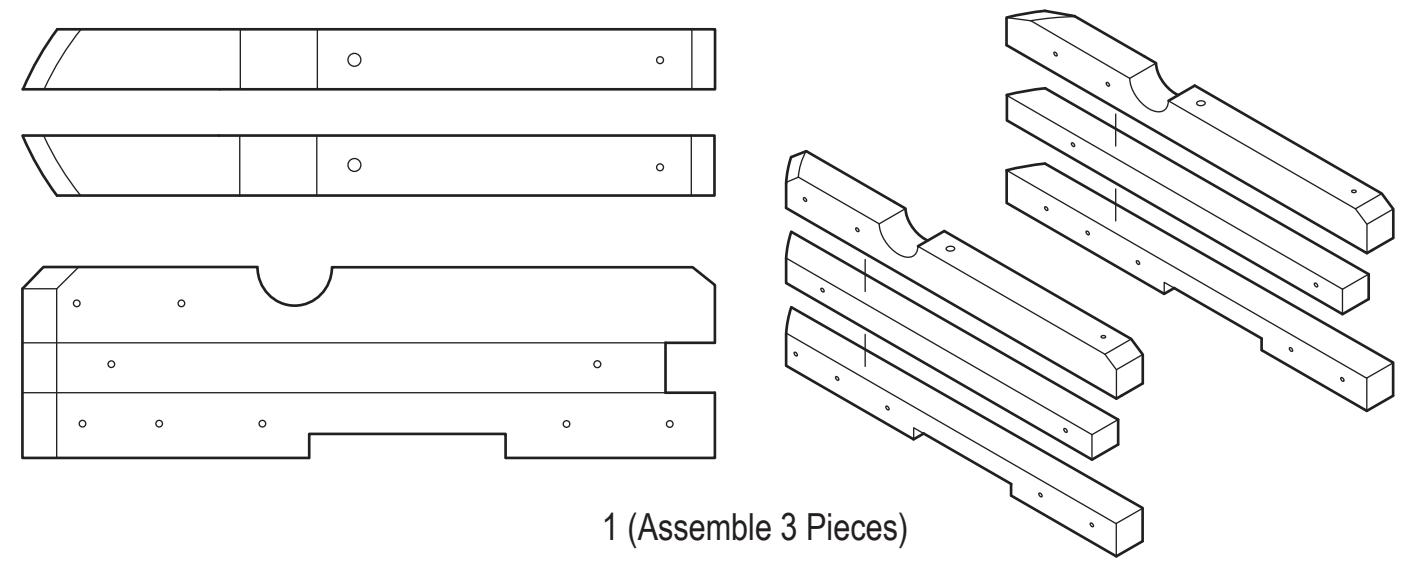

1 (Assemble 3 Pieces)

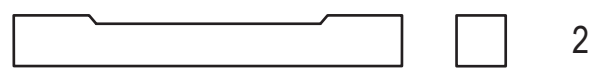

2

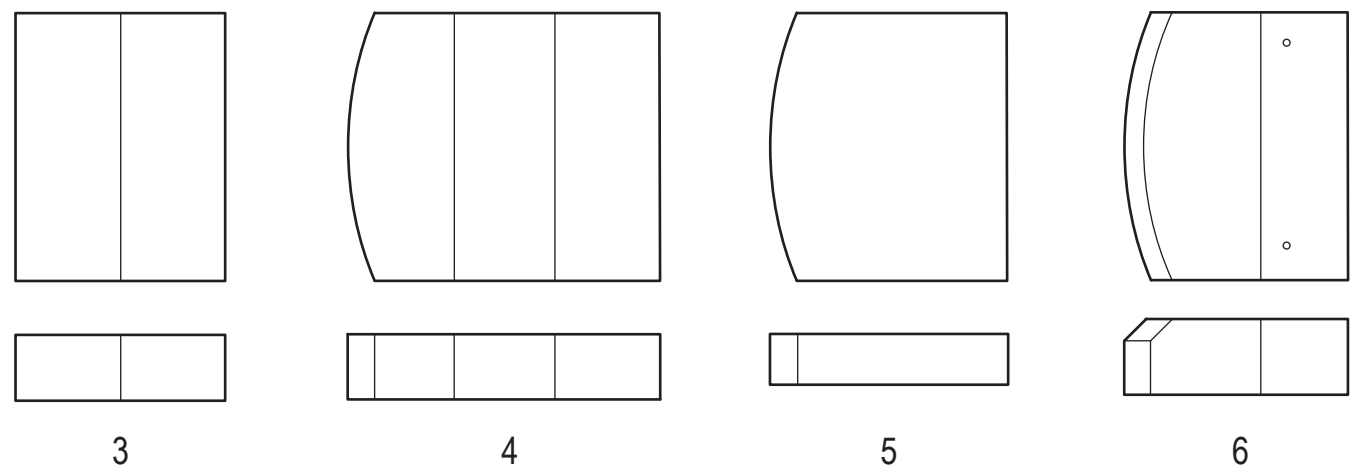

3

4

5

6

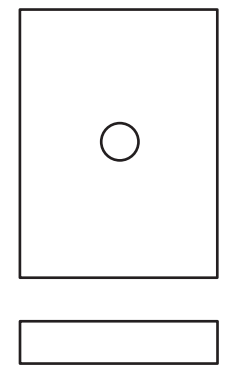

7

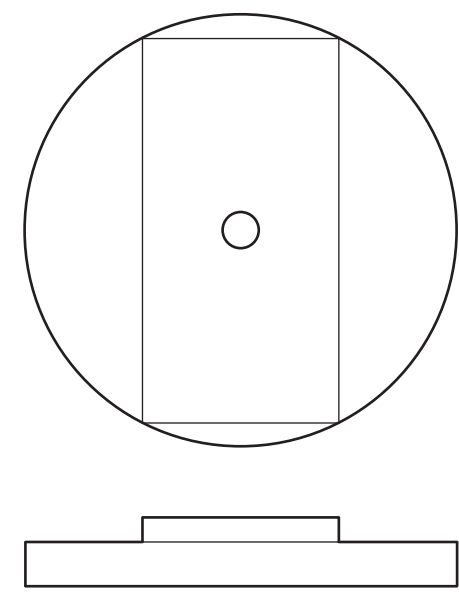

8

(Assemble 2 Pieces)

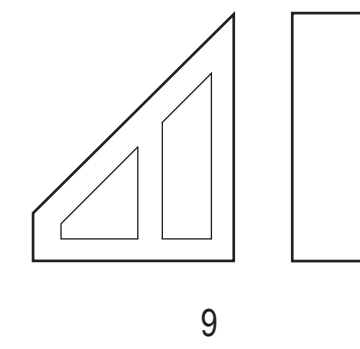

9

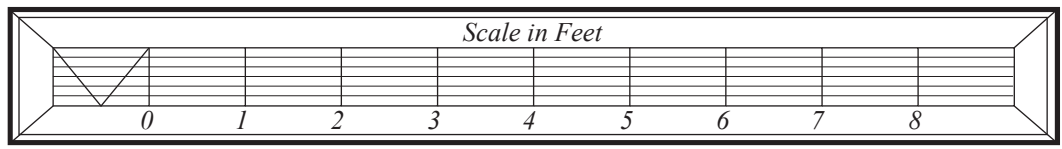
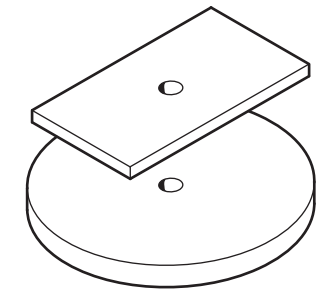

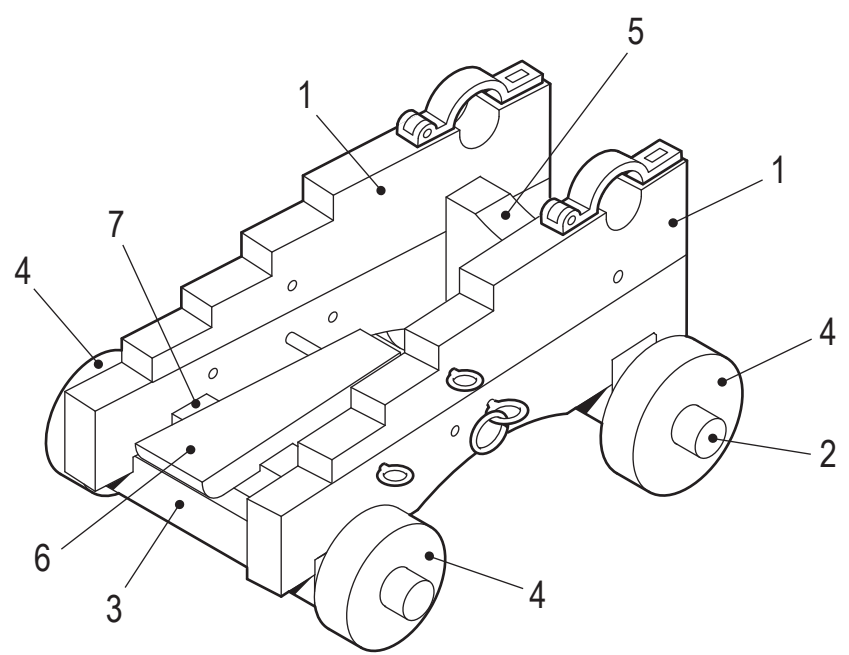
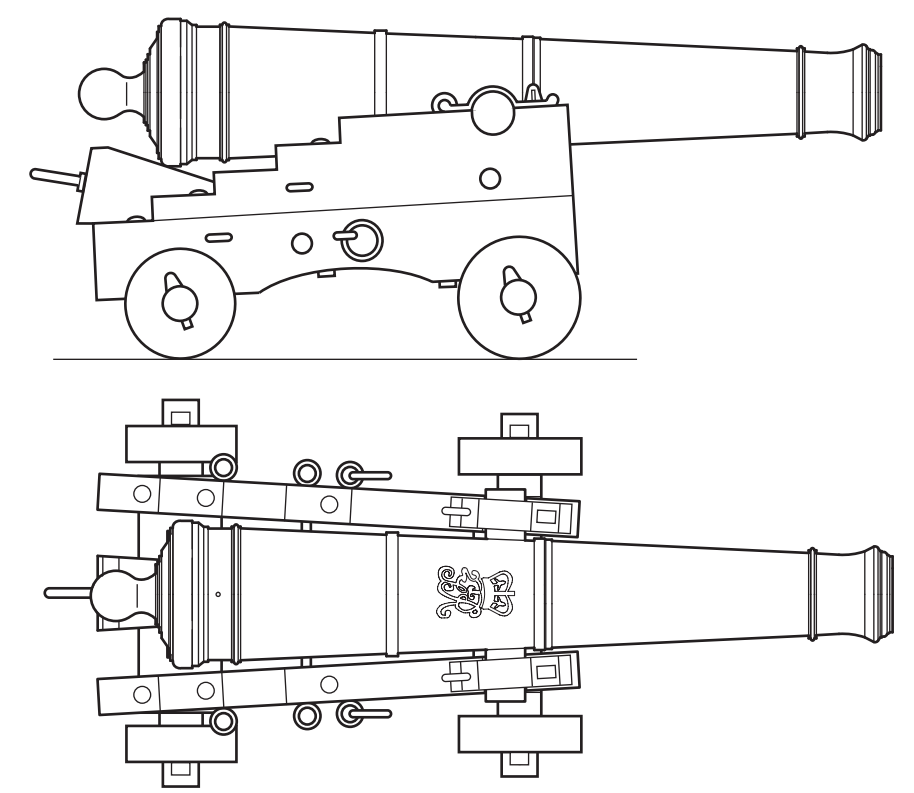
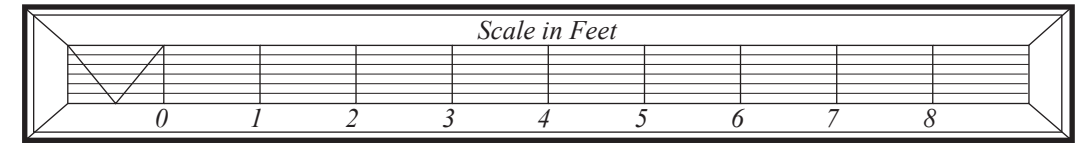
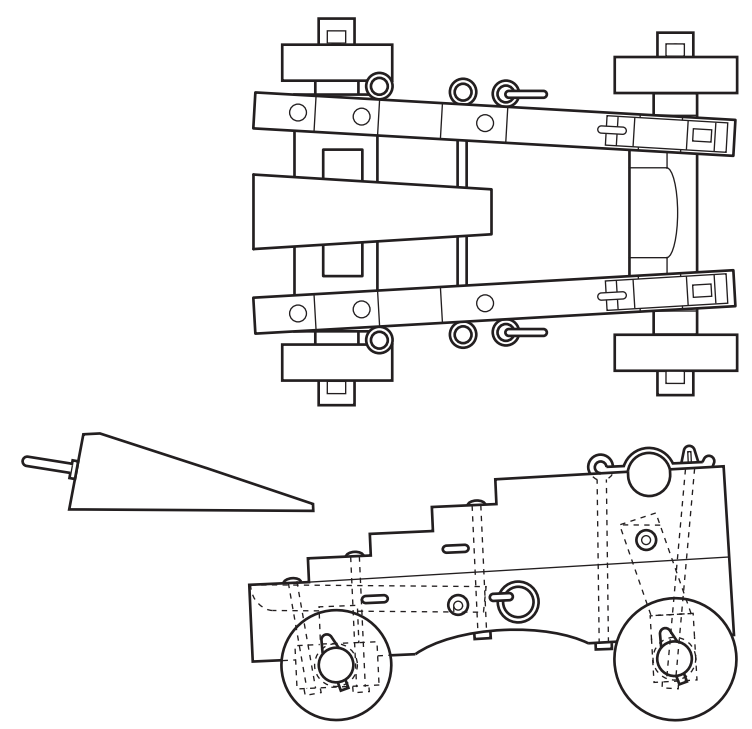
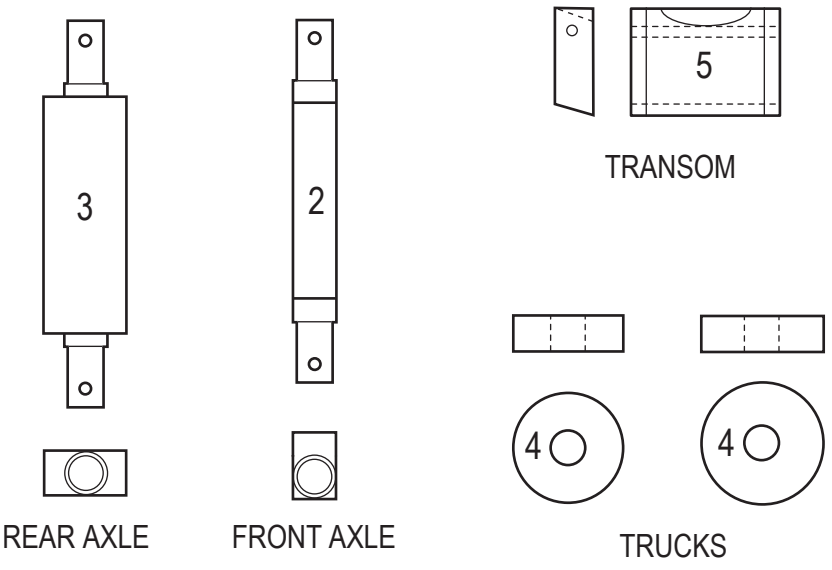
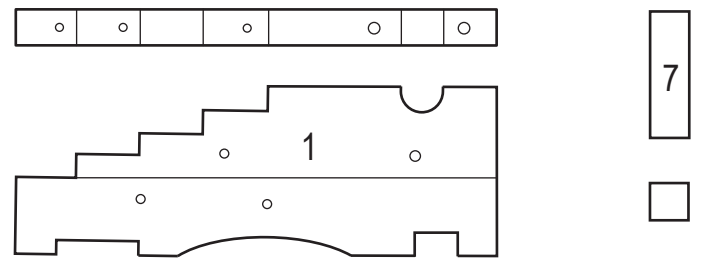
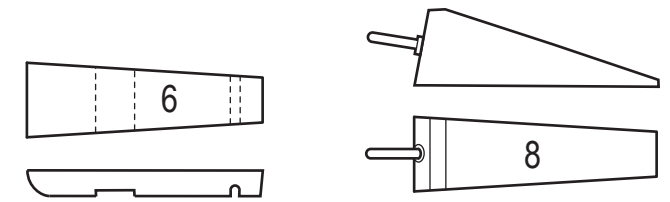
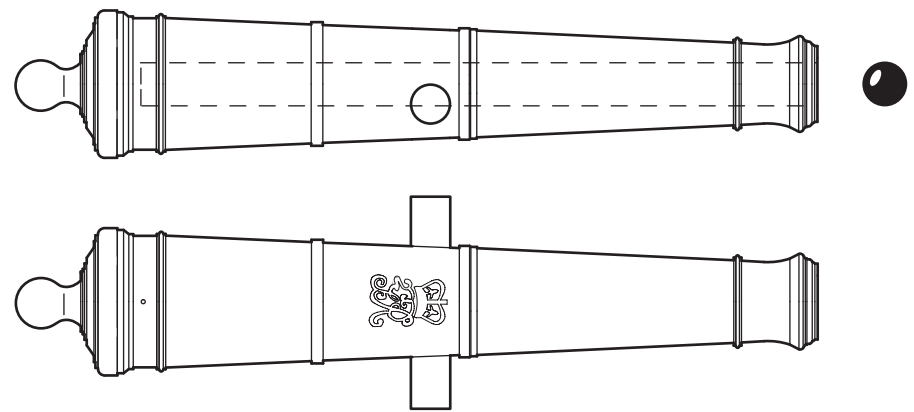

ModelShipBuilder  
www.modelshipbuilder.com

**BOMB VESSEL**  
1742  
**12 POUNDER GUN**

- 1. Bracket
- 2. Front Axle
- 3. Rear Axle
- 4. Trucks
- 5. Transom
- 6. Stool Bed
- 7. Bolster
- 8. Quoin



www.modelshipbuilder.com



### DECK ARRANGEMENT

- 1. Entry Port Ladder
- 2. Cleat
- 3. Kevel Cleat
- 4. Kevel Cleat
- 5. Ring Bolts

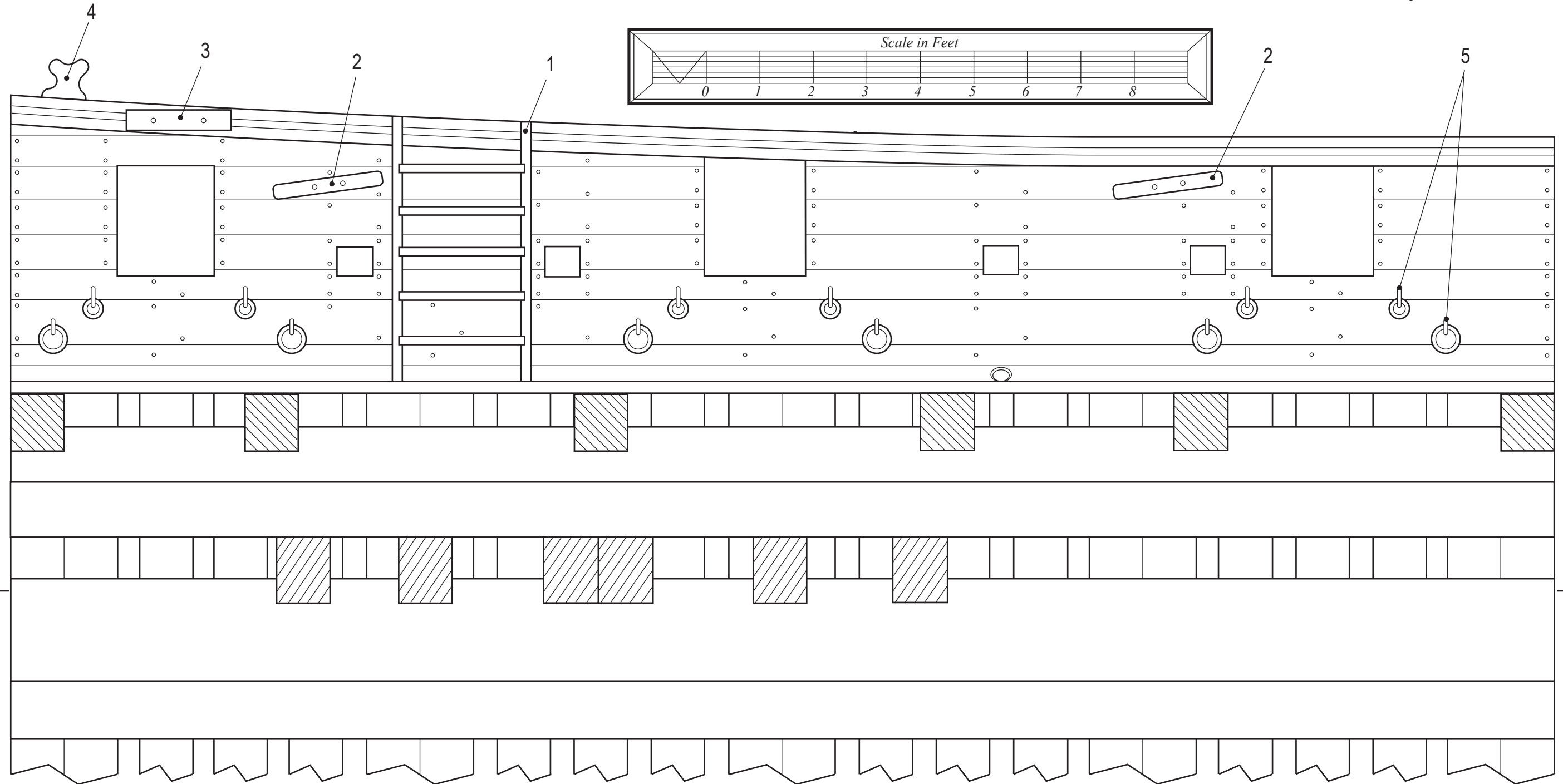
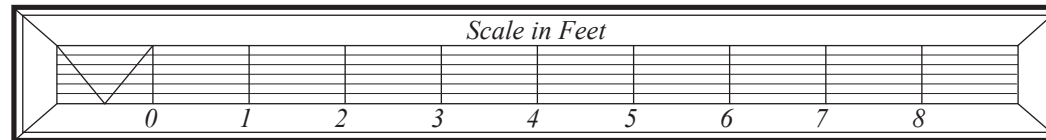
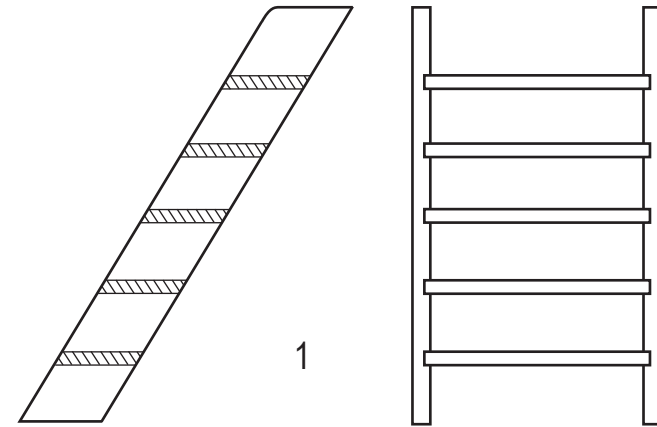
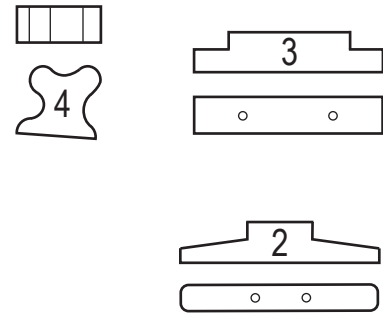

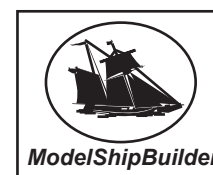
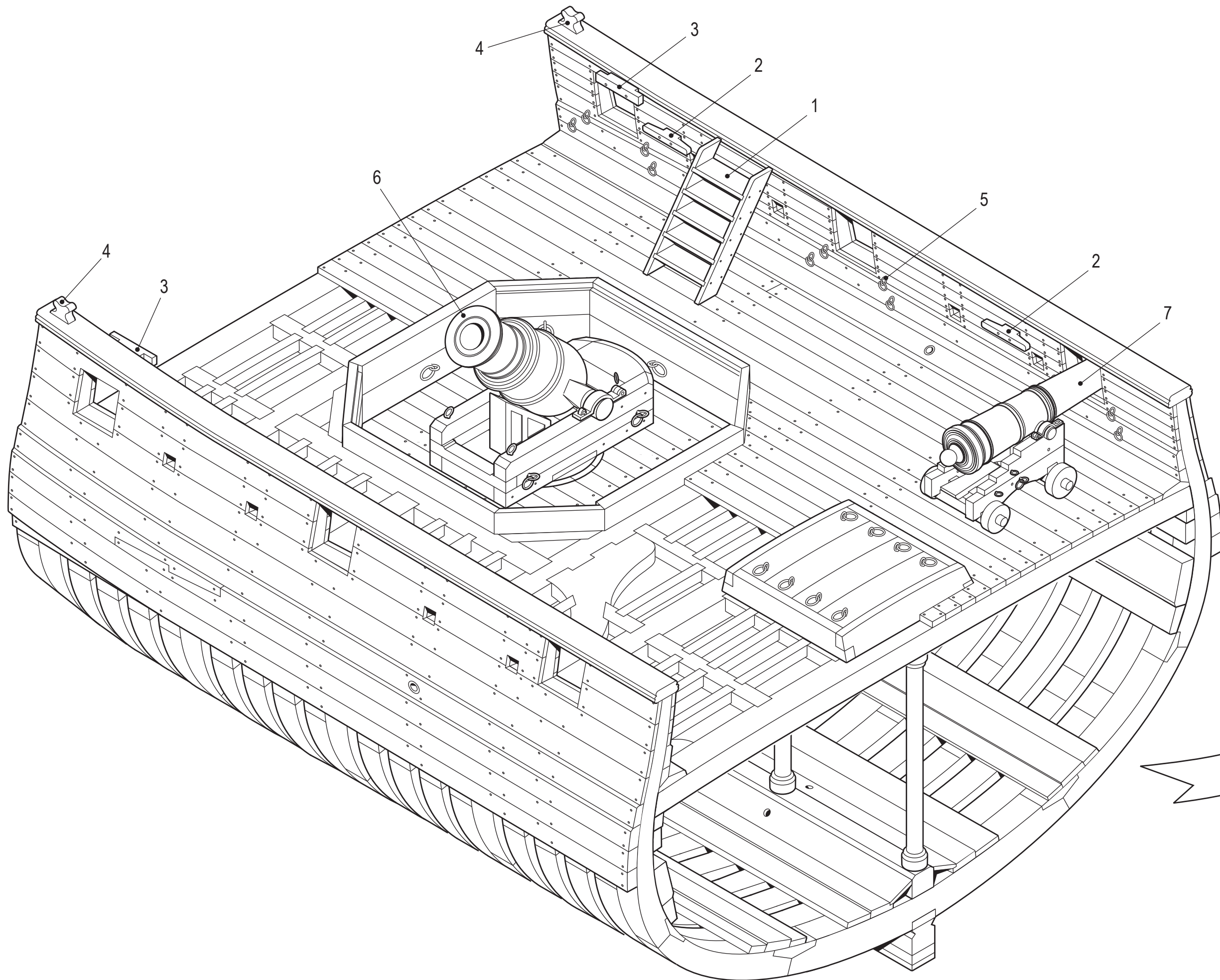

ModelShipBuilder

[www.modelshipbuilder.com](http://www.modelshipbuilder.com)

◦ BOMB VESSEL ◦

1742

**DECK ARRANGEMENT**

1. Entry Port Ladder
2. Cleat
3. Kevel Cleat
4. Kevel Cleat
5. Ring Bolts
6. Mortar (In Firing Position)
7. 12 Pounder Gun

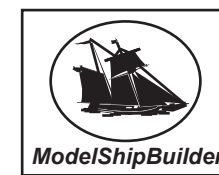
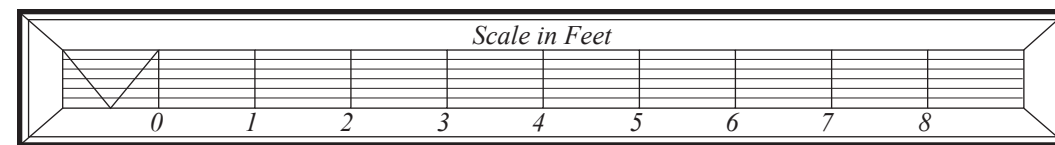
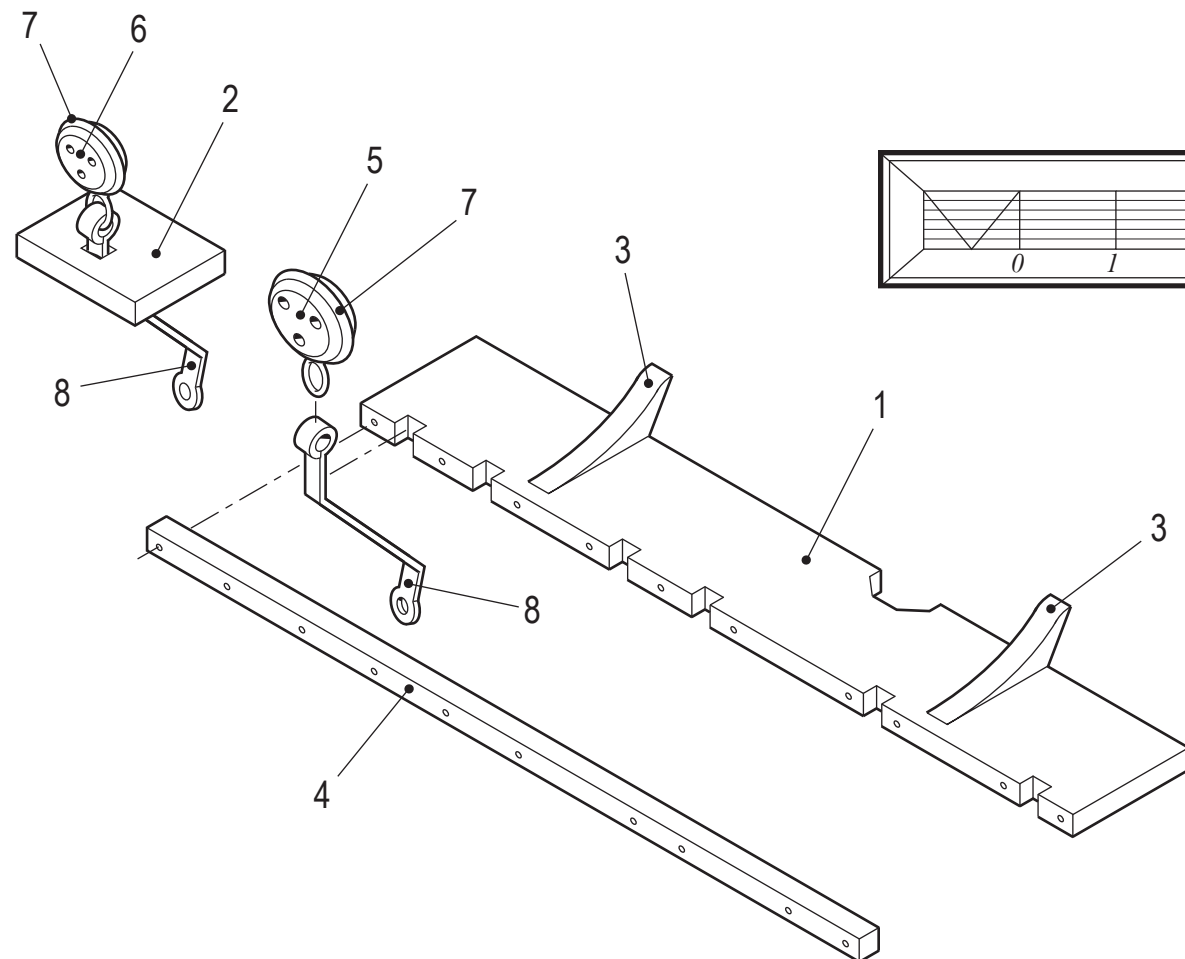
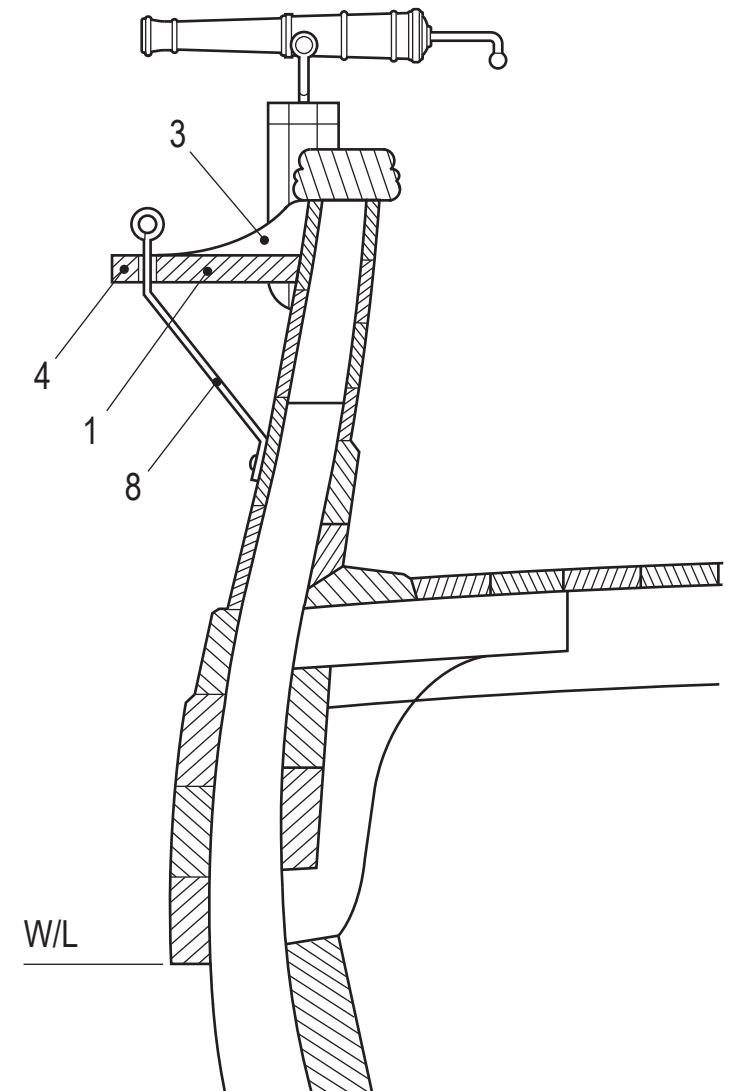
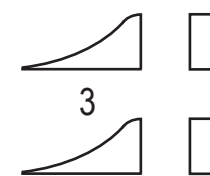
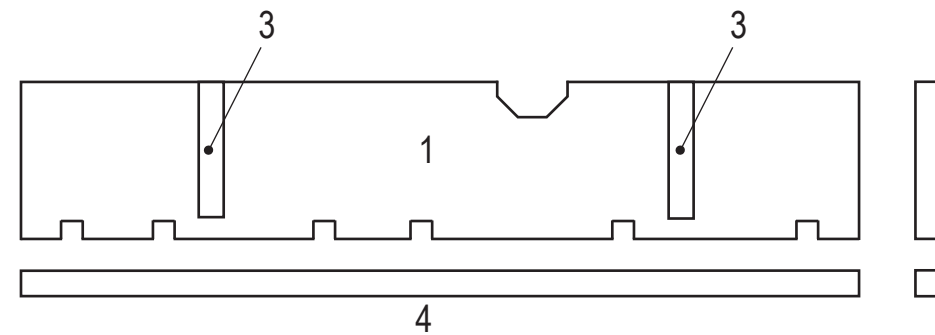
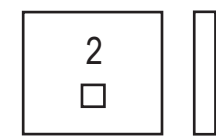
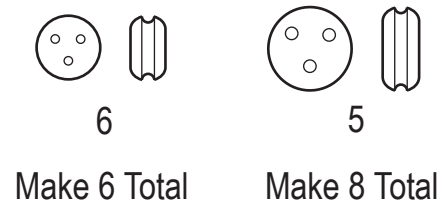
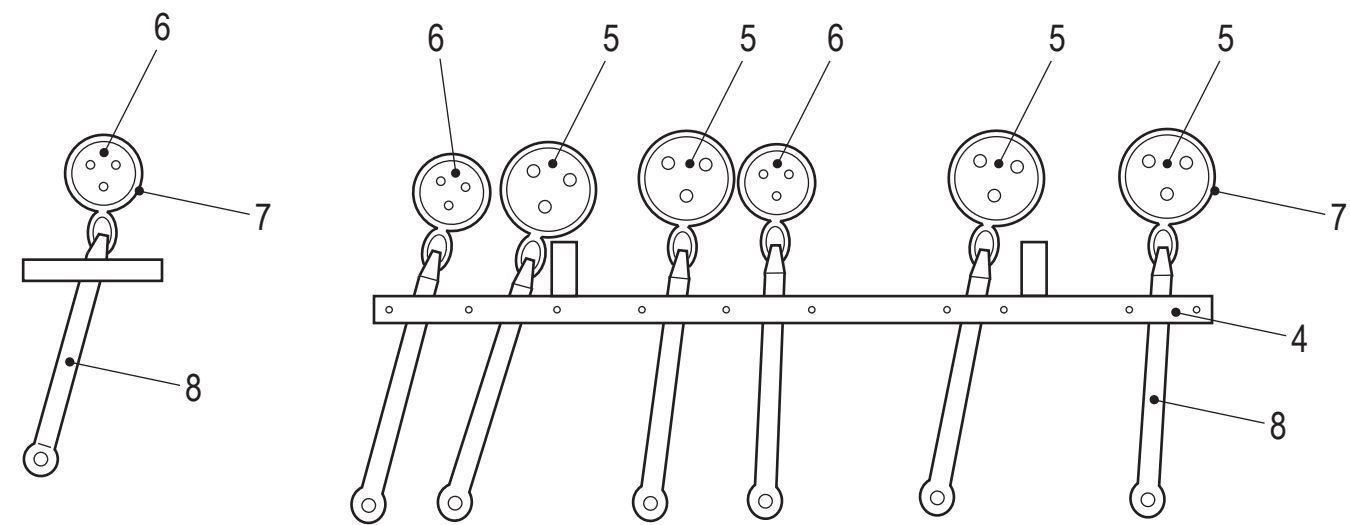

www.modelshipbuilder.com



**CHANNELS & DEADEYES**

- 1. Channel Board
- 2. Backstay Stool
- 3. Channel Knee
- 4. Retaining Paunch
- 5. Deadeye
- 6. Deadeye
- 7. Iron Chain Strop
- 8. Chain Plate

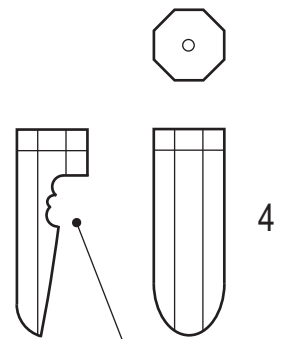

Fashion Pedestal to fit Hull.

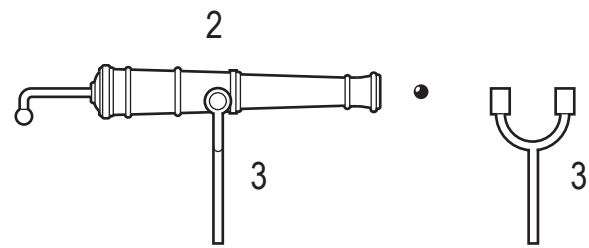

Make 10 Sets



**HULL ACCESSORIES**

- 1. Entry Port Ladder
- 2. Swivel Gun
- 3. Mounting Yoke
- 4. Swivel Gun Pedestal
- 5. Channels & Deadeyes

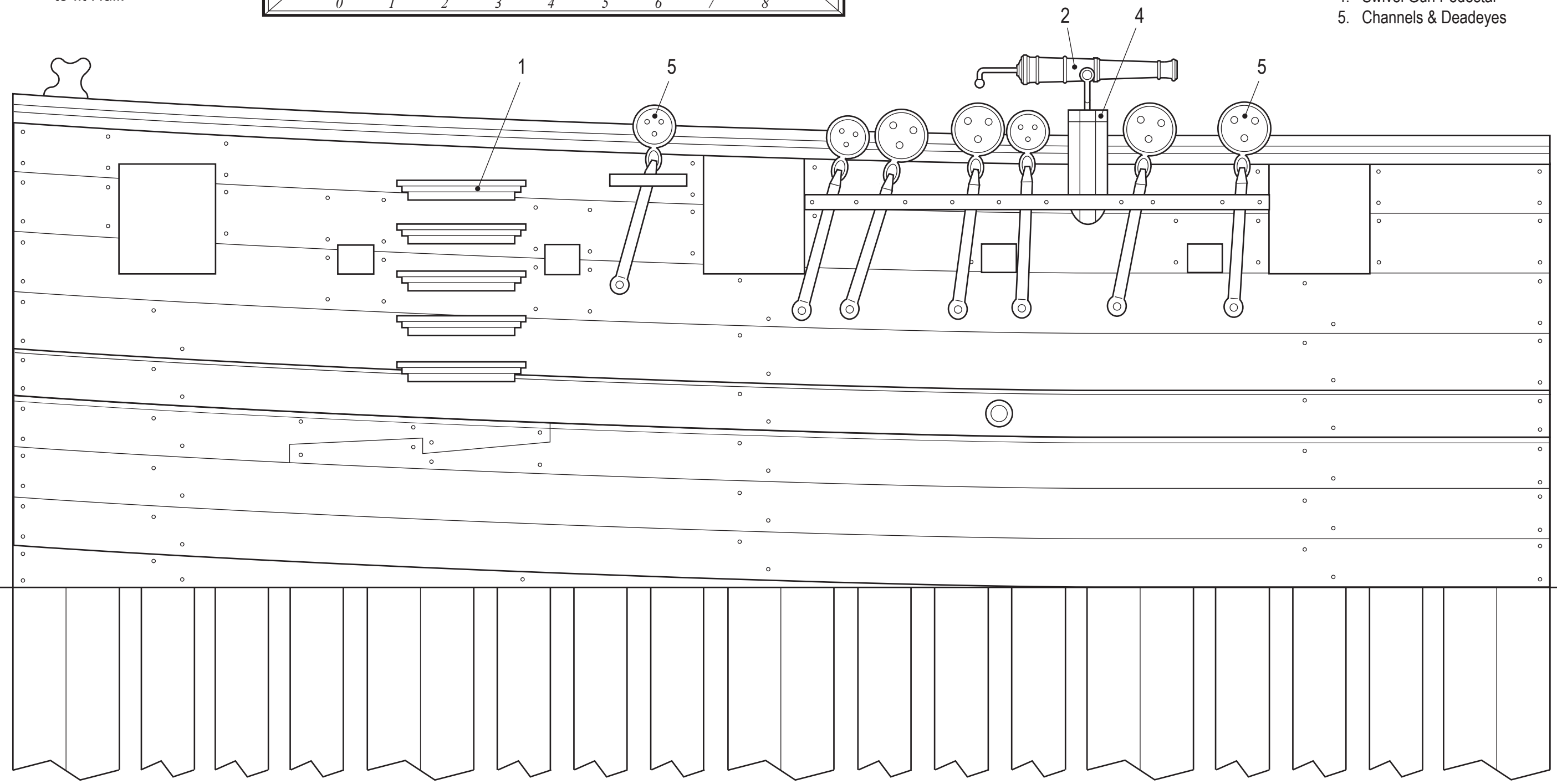
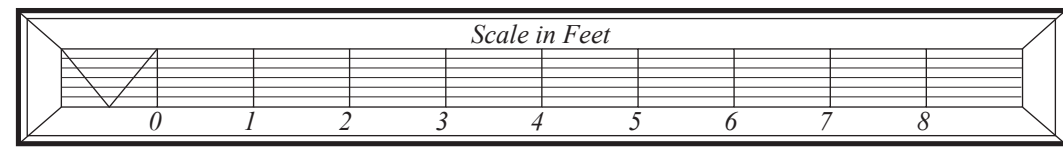

W/L

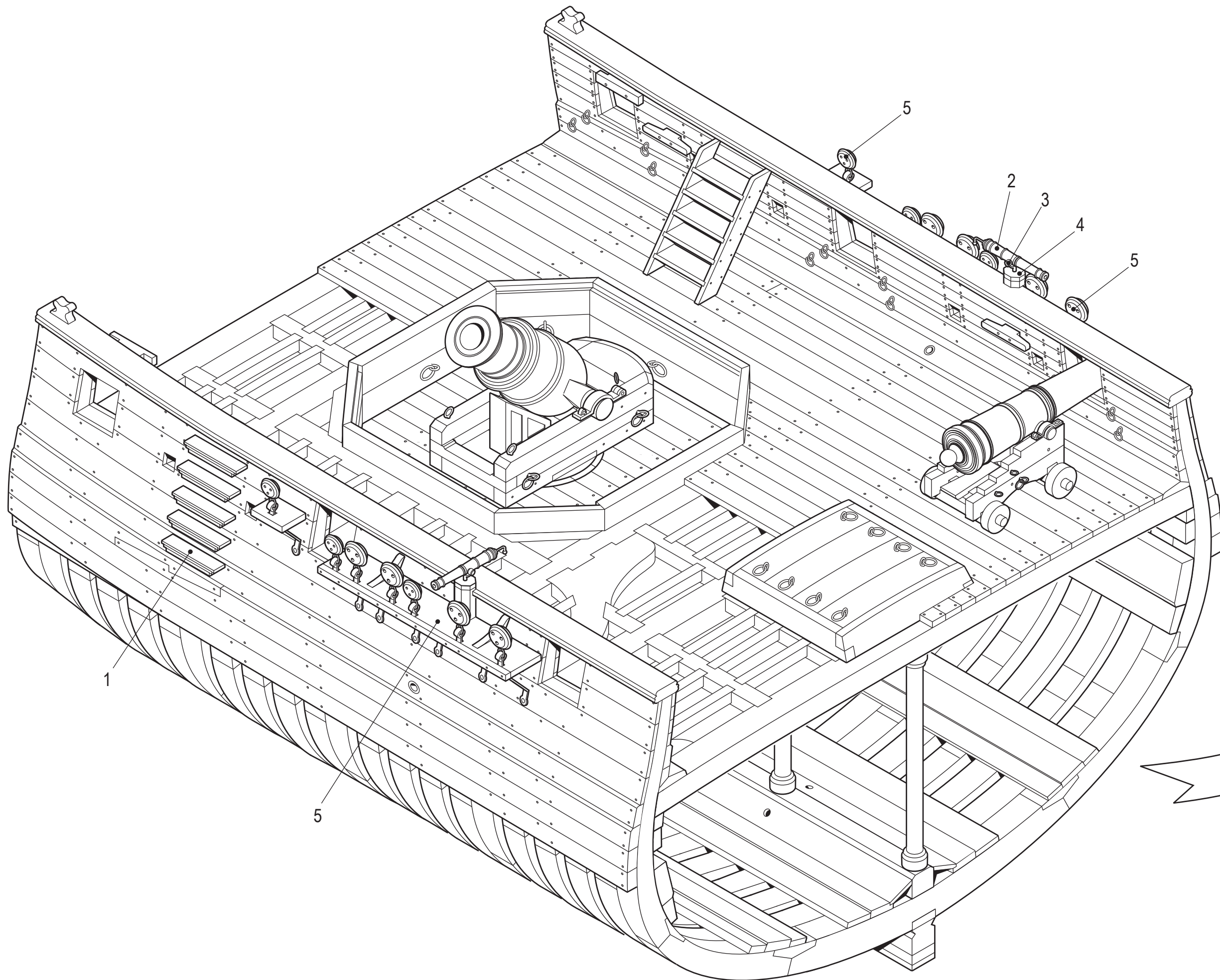

ModelShipBuilder

[www.modelshipbuilder.com](http://www.modelshipbuilder.com)

◦ BOMB VESSEL ◦

1742

**DECK ARRANGEMENT**

1. Entry Port Ladder
2. Swivel Gun
3. Mounting Yoke
4. Swivel Gun Pedestal
5. Channels & Deadeyes

**MORTAR PIT HOUSING (OPTIONAL)**

1. Transverse Bulkhead (Removable)
2. Bulkhead (Removable)
3. Strongback (Removable)
4. Side Cover
5. Canopy
6. Canopy Transom
7. Lifting Ring
8. Mortar

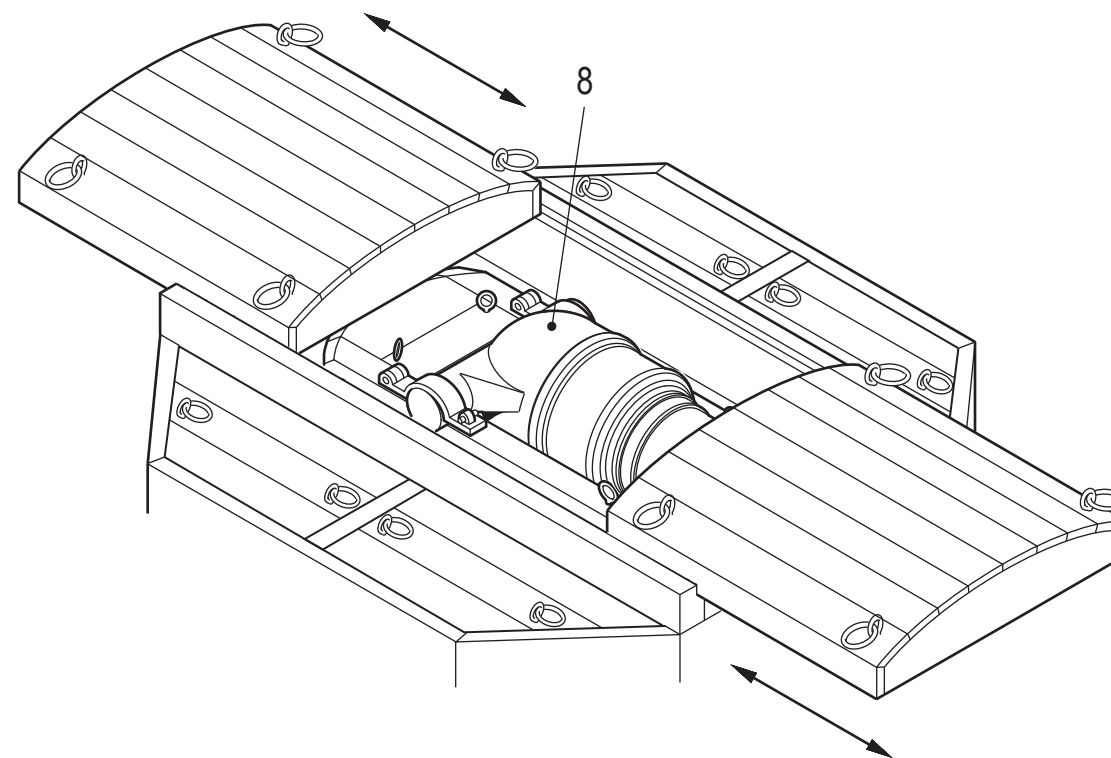
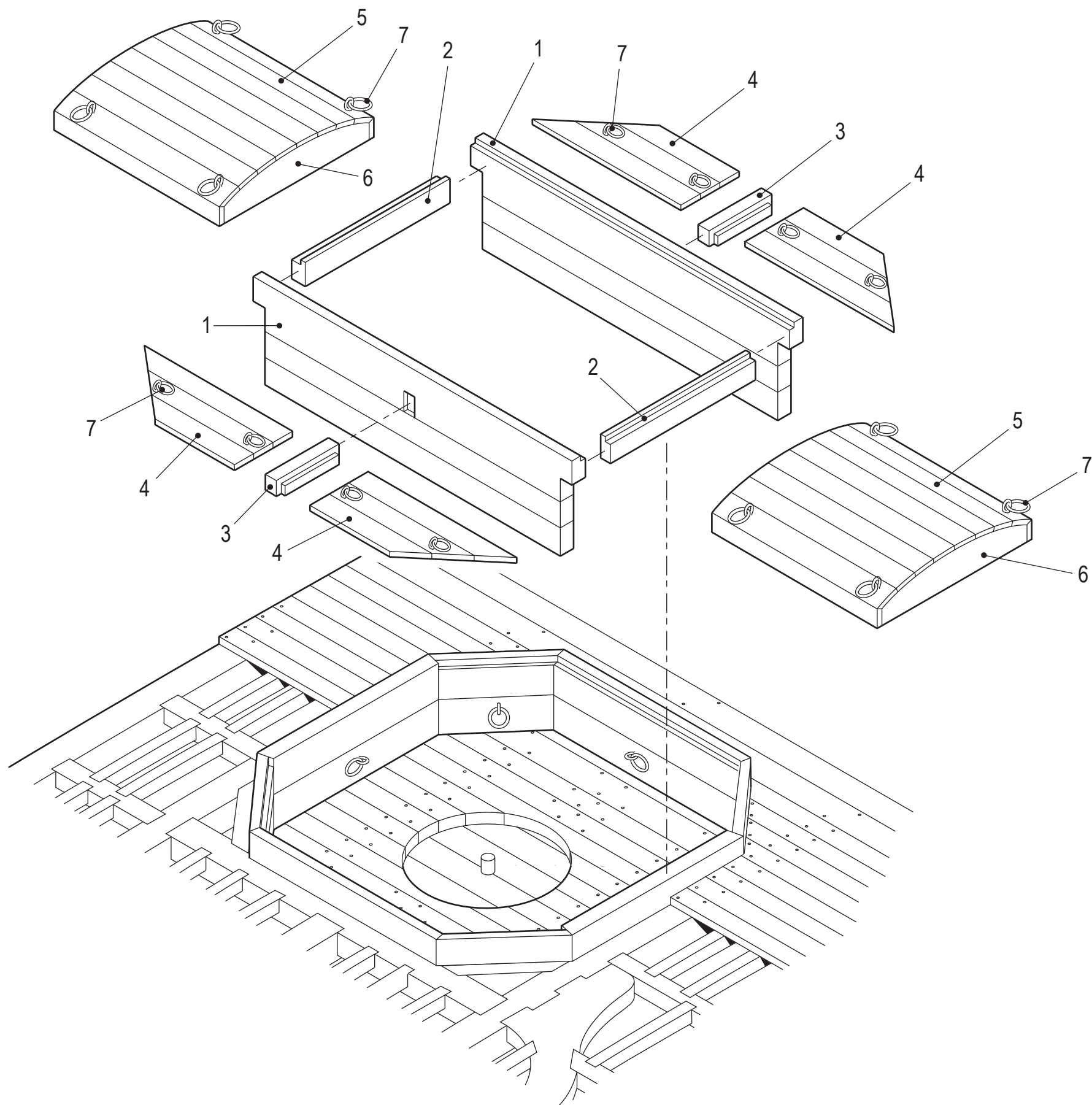

Cut 4 sets -  
part 4.

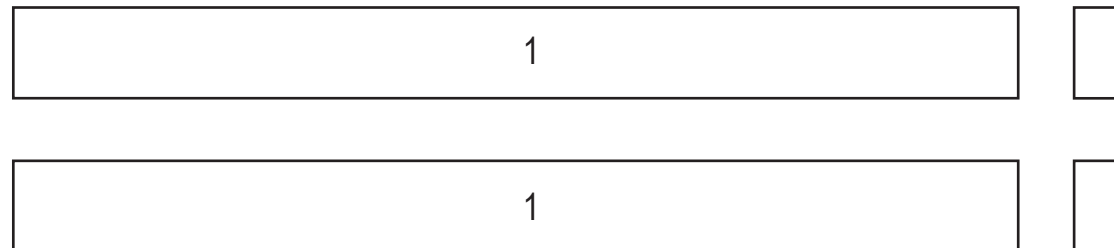
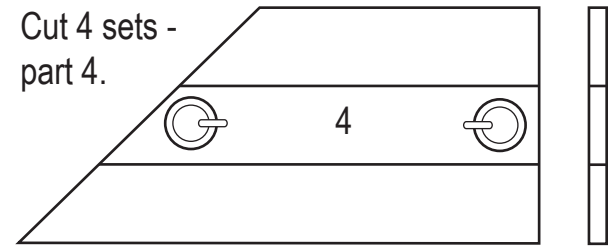

www.modelshipbuilder.com



**MORTAR PIT HOUSING (OPTIONAL)**

- 1. Transverse Bulkhead (Removable)
- 2. Bulkhead (Removable)
- 3. Strongback (Removable)
- 4. Side Cover
- 5. Canopy
- 6. Canopy Transom

Cut 2 sets -  
parts 1,2,3,5 and 6.

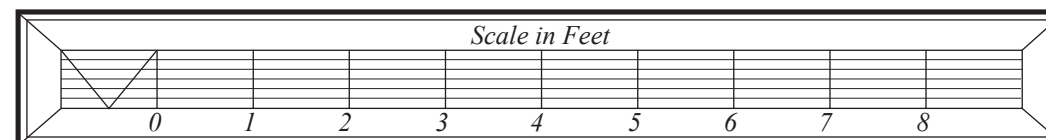
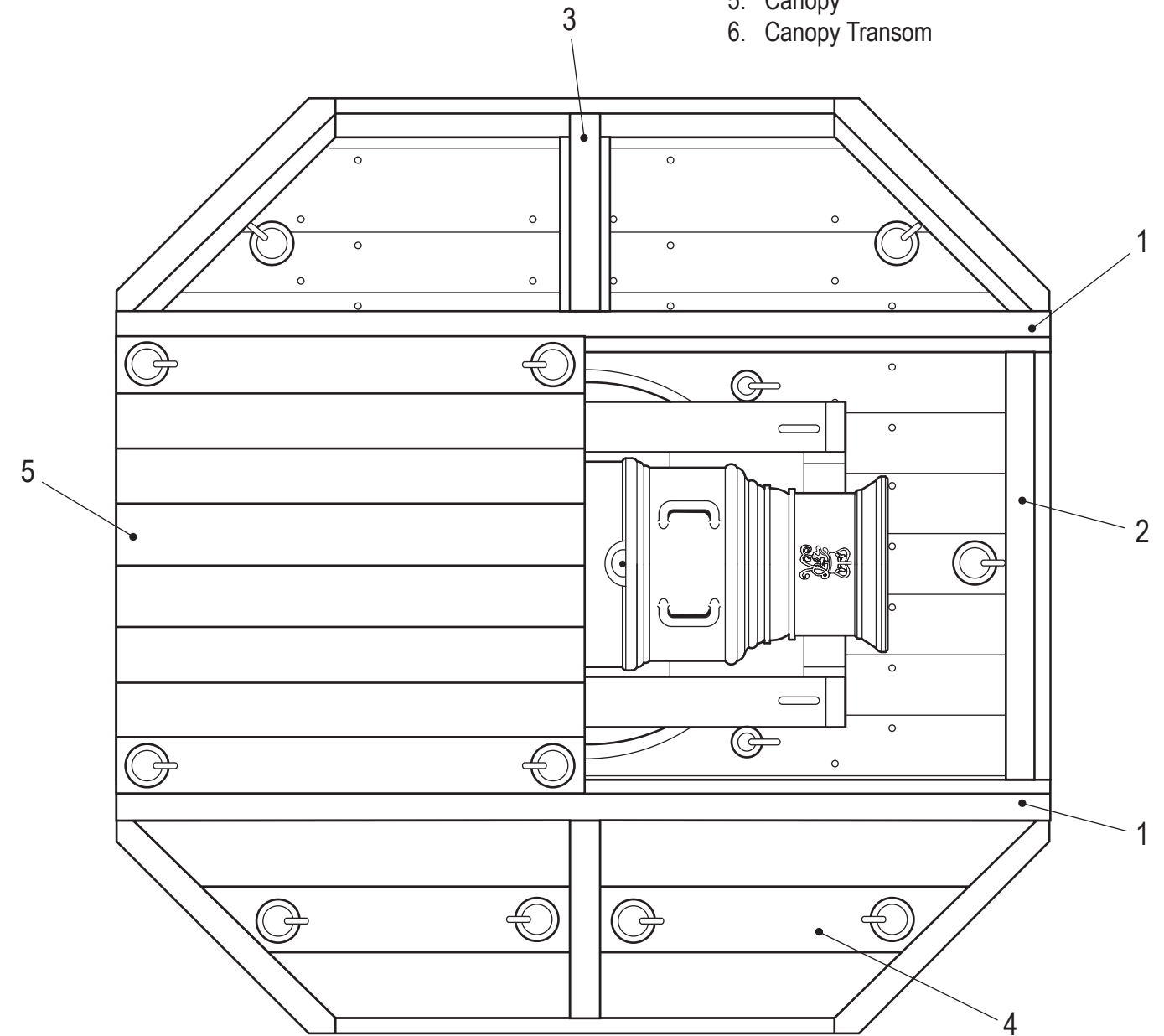
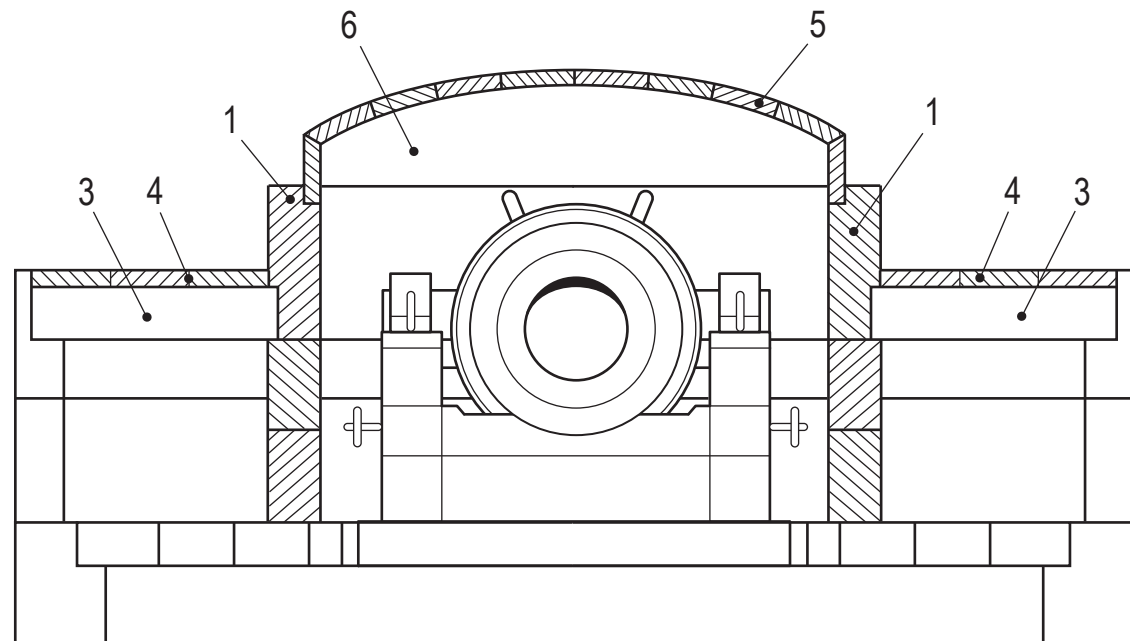
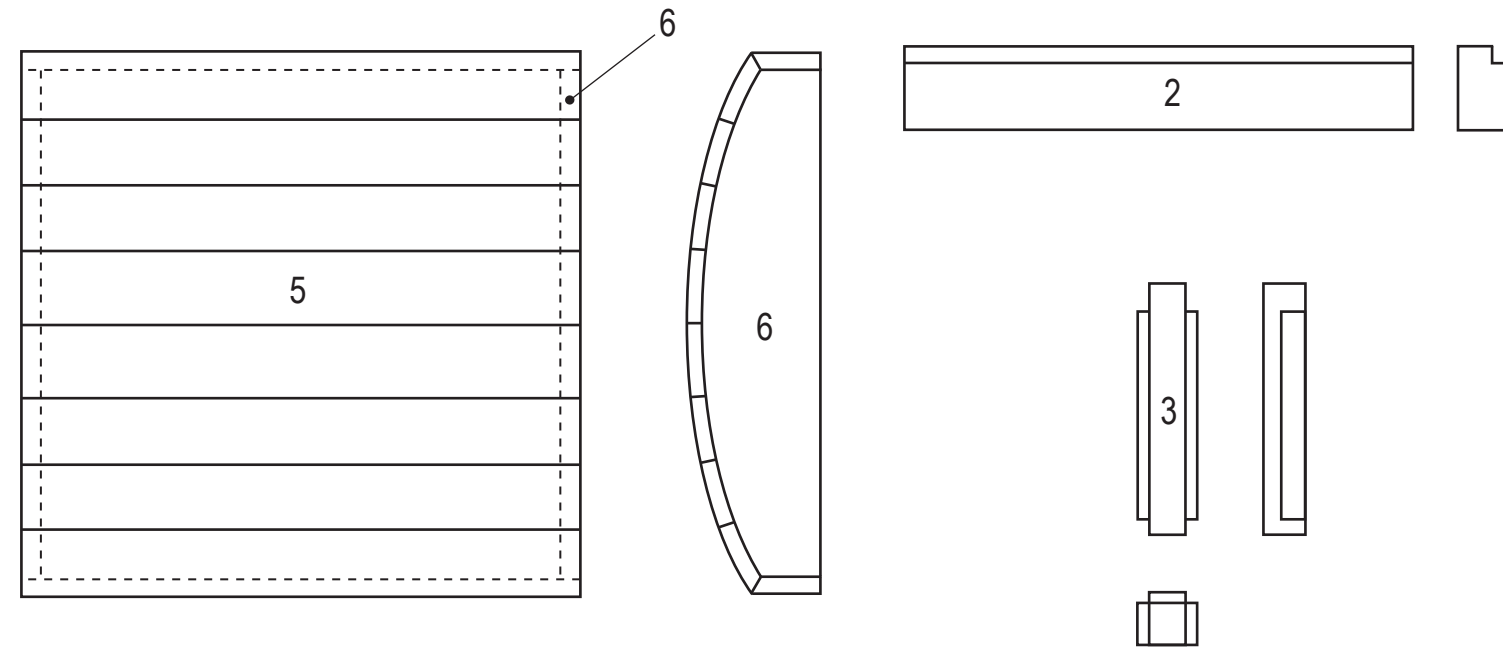



www.modelshipbuilder.com

◦ BOMB VESSEL ◦  
◡ 1742 ◡

**CRADLE**

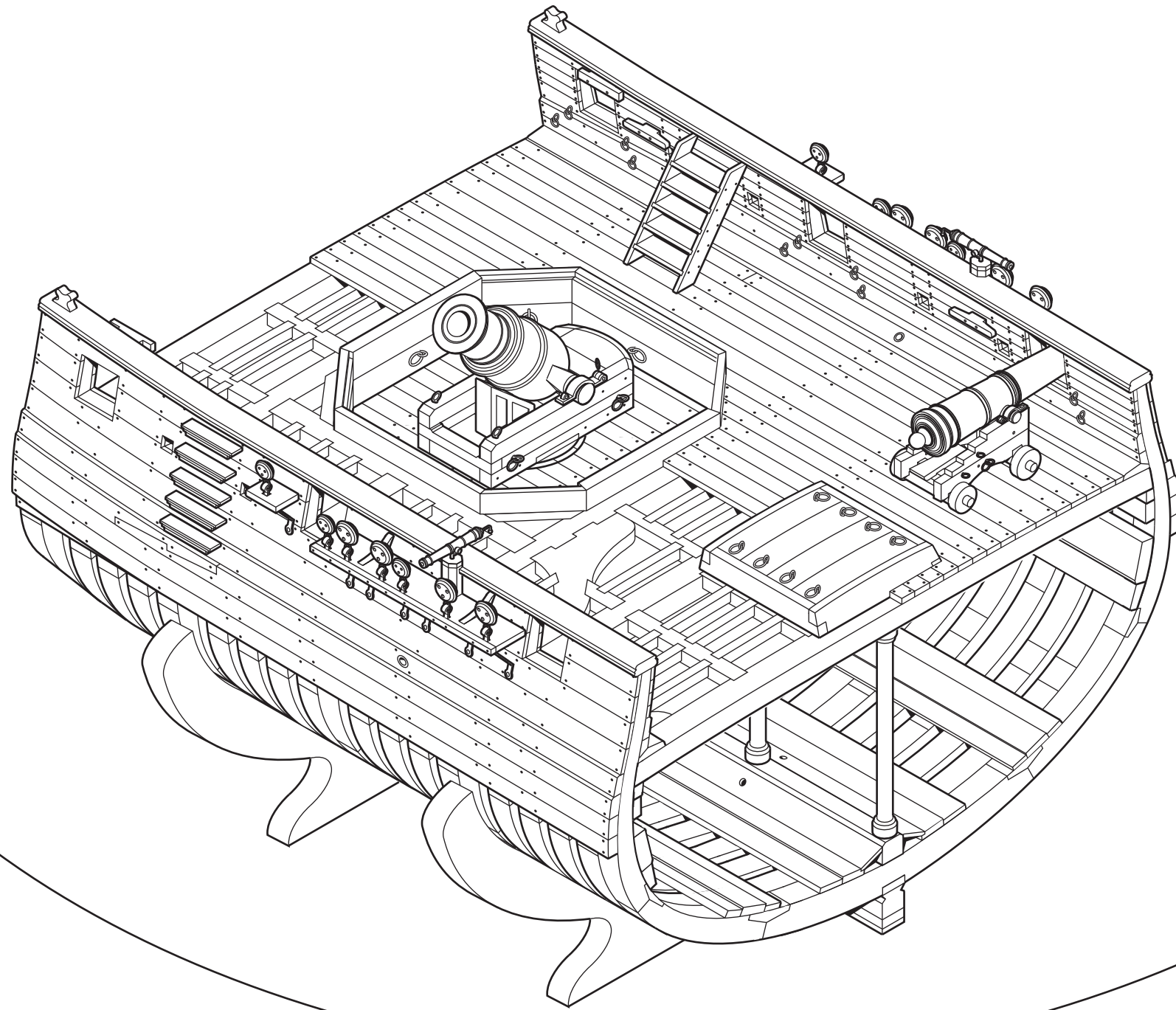

Cut 2 - 1/2" Material Thickness